

**\*\*KEEP THIS MANUAL\*\***

TARCO® WINDY 400  
SAFETY MANUAL

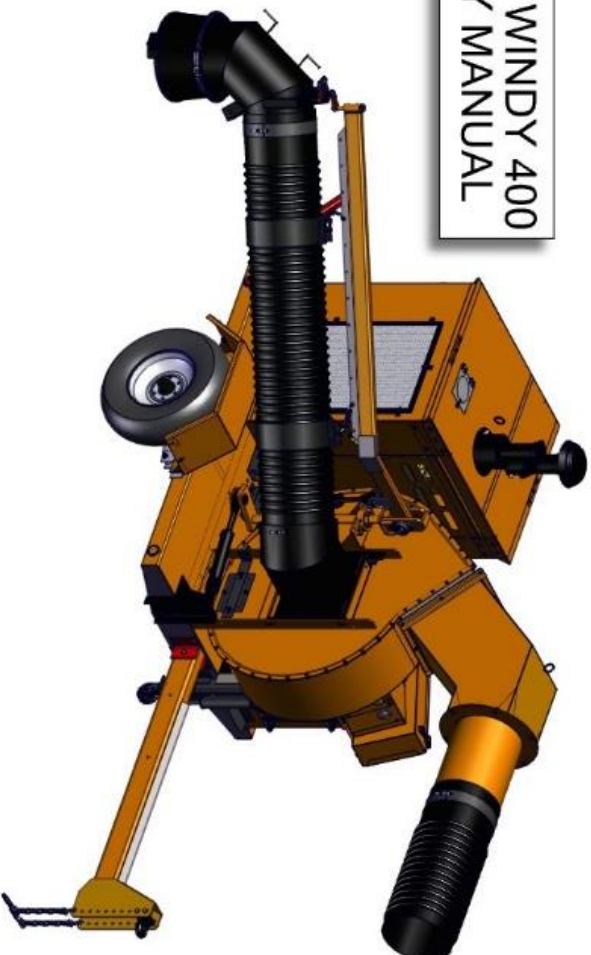

**FORT MILLER**  
**FAB3**

FORT MILLER FAB3 CORP.  
678 WILBUR AVE.  
GREENWICH, NY 12834  
[www.fmfab3.com](http://www.fmfab3.com)  
TEL. 518-584-4400  
FAX. 518-584-6630

  
**WARNING**

Read and understand operator's manual before using this equipment.  
Failure to follow operating instructions could result in death or serious injury.

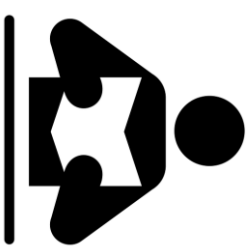

**\*\*IMPORTANT SAFETY INFORMATION\*\***



Thank you and congratulations on your recent purchase.  
Please take time reading and understanding the manual before operating the equipment.  
Fill in the following information, so that it is at hand when needed.

MODEL \_\_\_\_\_  
SERIAL NO. \_\_\_\_\_  
DATE OF PURCHASE \_\_\_\_\_



**\*\*\*The operator must carefully read and follow any warnings, safety sign and instructions provided with or located on the equipment.\*\*\***

**\*\*\*Please keep a copy of the manual in the cab so that it may be consulted by the operator.\*\*\***





**\*\*\*Do not allow untrained operators to use this equipment as serious injury, death or equipment damage could result.\*\*\***

\*\*\*FOR WARNING/NOTICE DECALS THAT ARE MISSING OR NOT LEGIBLE, OR FOR MANUAL REPLACEMENT COPIES, OR IF YOU HAVE QUESTIONS OR CONCERNS CONTACT FORT MILLER FAB3\*\*\*  
(518)-584-4400 or [www.fmfab3.com](http://www.fmfab3.com)

**\*\*IMPORTANT SAFETY INFORMATION\*\***

**SIGNAL WORDS & DEFINITIONS**

*\*SYMBOLS USED IN THE MANUAL AND ON THE MACHINERY\**

	<b>SAFETY ALERT SYMBOL USED TO ALERT OF POTENTIAL PERSONAL INJURY HAZARDS. OBEY ALL SAFETY MESSAGES THAT FOLLOW THIS SYMBOL TO AVOID POSSIBLE INJURY OR DEATH.</b>
	<b>DANGER INDICATES A HAZARDOUS SITUATION WHICH, IF NOT AVOIDED, WILL RESULT IN DEATH OR SERIOUS INJURY.</b>
	<b>WARNING INDICATES A HAZARDOUS SITUATION WHICH, IF NOT AVOIDED, COULD RESULT IN DEATH OR SERIOUS INJURY.</b>
	<b>CAUTION USED WITH THE SAFETY ALERT SYMBOL, INDICATES A HAZARDOUS SITUATION WHICH, IF NOT AVOIDED, COULD RESULT IN MINOR OR MODERATE INJURY.</b>
	<b>NOTICE IS USED TO ADDRESS PRACTICES NOT RELATED TO PERSONAL INJURY.</b>

**\*\*\*FOR WARNING/NOTICE DECALS THAT ARE MISSING OR NOT LEGIBLE, OR FOR MANUAL REPLACEMENT COPIES, OR IF YOU HAVE QUESTIONS OR CONCERNS CONTACT FORT MILLER FAB3\*\*\***

(518)-584-4400 or [www.fmfab3.com](http://www.fmfab3.com)

**\*\*IMPORTANT SAFETY INFORMATION\*\***



**A WARNING SYMBOL INDICATES A HAZARDOUS SITUATION WHICH, IF NOT AVOIDED, COULD RESULT IN SERIOUS INJURY OR DEATH.**



- **⚠ WARNING** DO NOT OPERATE MACHINERY WITHOUT READING AND UNDERSTANDING THIS MANUAL. **FAILURE TO FOLLOW THIS INFORMATION CAN LEAD TO MACHINE DAMAGE, SERIOUS INJURY, OR EVEN DEATH.**
- **⚠ WARNING** USE ALL MACHINERY FOR ITS INTENDED USE. **FAILURE TO FOLLOW THIS INFORMATION CAN LEAD TO MACHINE DAMAGE, SERIOUS INJURY, OR EVEN DEATH.**
- **⚠ WARNING** DO NOT MODIFY EQUIPMENT. **FAILURE TO FOLLOW THIS INFORMATION CAN LEAD TO MACHINE DAMAGE, SERIOUS INJURY, OR EVEN DEATH.**
- **⚠ WARNING** ANY MISS USE OR MODIFICATION TO THE EQUIPMENT **CAN LEAD TO MACHINE DAMAGE, SERIOUS INJURY, OR EVEN DEATH.**
- **⚠ WARNING** DO NOT RIDE ON MACHINERY. **FAILURE TO FOLLOW THIS INFORMATION CAN LEAD TO MACHINE DAMAGE, SERIOUS INJURY, OR EVEN DEATH.**

\*\*\*FOR WARNING/NOTICE DECALS THAT ARE MISSING OR NOT LEGIBLE, OR FOR MANUAL REPLACEMENT COPIES, OR IF YOU HAVE QUESTIONS OR CONCERNS CONTACT FORT MILLER FAB3\*\*\*  
(518)-584-4400 or [www.fmfab3.com](http://www.fmfab3.com)

**\*\*IMPORTANT SAFETY INFORMATION\*\***

**IMPORTANT SAFETY INFORMATION**

**TO THE OPERATOR**

Prior to using the TARCO® WINDY 400, you must be properly trained in the full operation of the machine. This would include but not be limited to a complete review of the operating and safety manual and a complete understanding of all safety procedures including the safety decals and information on the machine. If there is something you do not understand, ask your supervisor to explain it to you. If you require additional manuals or decals, please contact your dealer or the manufacturer.

Make sure all the manufacturers' protective guards, shields, and screens are in good repair, in place, and securely fastened. Damaged, missing, or weakened safety components can create a hazardous situation for the operator. NEVER remove or modify any safety components on this equipment.

Wear all the protective clothing and personal safety devices issued to you or called for by the job conditions. This may include but is not limited to a hard hat, safety shoes, safety glasses or goggles, heavy gloves, hearing protection, reflective clothing or wet weather gear. Remember, you are responsible for your safety and that of your co-workers. Good safety practices protect you and the people around you.

**NEVER ride on any part of the equipment or trailer when operating the machine or at any time. Never modify the machine for riders in any way. Prior to operating this machine, be certain that all operators can ride safely in the truck or vehicle being used to trailer the machine. If your machine has been altered to accommodate riders, remove these alterations immediately as this can result in serious injury or death. A "NO RIDERS" decal should be in place. Please request these from your dealer or use the web to contact and request them from Fort Miller FAB3 Corp. (518)-584-4400 or [www.fmfab3.com](http://www.fmfab3.com).**

**\*\*IMPORTANT SAFETY INFORMATION\*\***



**A WARNING SYMBOL INDICATES A HAZARDOUS SITUATION WHICH, IF NOT AVOIDED, COULD RESULT IN SERIOUS INJURY OR DEATH**



**⚠ WARNING** DO NOT operate unit without wearing proper safety equipment as described in this manual.

**⚠ WARNING** DO NOT operate, maintain or repair this unit without fully reading and understanding ALL aspects of this manual.

**⚠ WARNING** DO NOT lubricate, make any adjustment or repairs before proper LOCK OUT/TAG OUT is performed.

**⚠ WARNING** DO NOT operate the unit while under the influence of alcohol, drugs, or any medication that could impair operating abilities.

**⚠ WARNING** DO NOT operate the unit with ANY guards or safety devices broken, missing, or inoperable.

**⚠ WARNING** DO NOT operate the unit without fully inspecting the unit for any damage or leakage.

**⚠ WARNING** DO NOT use equipment that is not safe.

**⚠ WARNING** DO NOT operate the unit if all operating controls and safety devices are not in good working order.

**⚠ WARNING** DO NOT operate unit in a state of disrepair.

**⚠ WARNING** DO NOT ride, sit or stand on the unit while in use.

**⚠ WARNING** DO NOT place hands or feet near moving or rotating parts.

\*\*\*FOR WARNING/NOTICE DECALS THAT ARE MISSING OR NOT LEGIBLE, OR FOR MANUAL REPLACEMENT COPIES, OR IF YOU HAVE QUESTIONS OR CONCERNS CONTACT FORT MILLER FAB3\*\*\*

(518)-584-4400 or [www.fmfab3.com](http://www.fmfab3.com)

**\*\*\*IMPORTANT SAFETY INFORMATION\*\***

**⚠ WARNING** DO NOT jump from the vehicle.

**⚠ WARNING** DO NOT allow personnel to ride anywhere, except in the cab, when the unit or vehicle is in operation.

**⚠ WARNING** DO NOT modify the unit for any reason to allow for riders.

**⚠ WARNING** DO NOT exceed weight limitations.

**⚠ WARNING** DO NOT smoke or weld near the unit.

**⚠ WARNING** DO NOT leave machine running unattended.

**⚠ WARNING** DO NOT park unit on a steep grade or slope.

**⚠ WARNING** DO NOT operate the unit until all hydraulic components are checked for leaks and damage, and repaired if found.

**⚠ WARNING** DO NOT tow the unit without attaching all the safety chains and the breakaway cable.

**⚠ WARNING** DO NOT tow the unit with a damaged tongue.

**⚠ WARNING** DO NOT fill the fuel tank with the engine running. Allow engine to cool before refueling.

**⚠ WARNING** DO NOT operate the unit if fuel is spilled or with cap off.

**⚠ WARNING** DO NOT run the engine in an enclosed area.

**⚠ WARNING** DO NOT operate engine with an accumulation of combustible material on or around the engine.

**⚠ WARNING** DO NOT run engine with air cleaner removed.

**⚠ WARNING** DO NOT operate the unit if there is excessive vibration, shut down and repair immediately.

**⚠ WARNING** DO NOT vacuum a leaf pile without first looking for foreign objects.

\*\*\*FOR WARNING/NOTICE DECALS THAT ARE MISSING OR NOT LEGIBLE, OR FOR MANUAL REPLACEMENT COPIES, OR IF YOU HAVE QUESTIONS OR CONCERNS CONTACT FORT MILLER FAB3\*\*\*

(518)-584-4400 or [www.fmfab3.com](http://www.fmfab3.com)

**\*\*IMPORTANT SAFETY INFORMATION\*\***



**A WARNING SYMBOL INDICATES A HAZARDOUS SITUATION WHICH, IF NOT AVOIDED, COULD RESULT IN SERIOUS INJURY OR DEATH**



**⚠ WARNING DO** wear proper safety equipment as described in this manual.

**⚠ WARNING DO** completely read and understand the owner's manual before operating, maintaining, or repairing this equipment.

**⚠ WARNING DO** perform proper LOCK OUT/TAG OUT before any adjustment or repairs are made.

**⚠ WARNING DO** remove the negative battery cable before doing any maintenance on the unit.

**⚠ WARNING DO** follow and obey ALL safety regulations.

**⚠ WARNING DO** replace any worn or missing safety decals immediately contact: (518)584-4400 or at [www.fmfab3.com](http://www.fmfab3.com)

**⚠ WARNING DO** completely inspect the unit before leaving the service garage.

**⚠ WARNING DO** watch for pedestrians, animals, and other foreign objects when operating this unit.

**⚠ WARNING DO** check the tow tongue before each use for cracks.

**⚠ WARNING DO** check the impeller, liners and blower housing for cracks and holes daily. Replace if necessary.

**\*\*\*FOR WARNING/NOTICE DECALS THAT ARE MISSING OR NOT LEGIBLE, OR FOR MANUAL REPLACEMENT COPIES, OR IF YOU HAVE QUESTIONS OR CONCERNS CONTACT FORT MILLER FAB3\*\*\*  
(518)-584-4400 or [www.fmfab3.com](http://www.fmfab3.com)**



**\*\*IMPORTANT SAFETY INFORMATION\*\***

**⚠ WARNING DO** watch for pedestrians, animals and other foreign material while vacuuming leaves.

**⚠ WARNING DO** inspect and be attentive to what is being vacuumed.

**⚠ WARNING DO** follow engine manufactures operating and maintenance instructions?

**⚠ WARNING DO** check fuel lines and fittings frequently for cracks or leaks. Replace if necessary.

**⚠ WARNING DO** wear proper safety equipment as described in this manual.

\*\*\*FOR WARNING/NOTICE DECALS THAT ARE MISSING OR NOT LEGIBLE, OR FOR MANUAL REPLACEMENT COPIES, OR IF YOU HAVE QUESTIONS OR CONCERNS CONTACT FORT MILLER FAB3\*\*\*  
(518)-584-4400 or [www.fmfab3.com](http://www.fmfab3.com)

**\*\*IMPORTANT SAFETY INFORMATION\*\***



**A WARNING SYMBOL INDICATES A HAZARDOUS SITUATION WHICH, IF NOT AVOIDED, COULD RESULT IN SERIOUS INJURY OR DEATH**

**⚠️WARNING** – Before starting the engine or applying power to the machine be sure the suction assembly is securely in place over the suction and discharge openings and ready for operation. Make sure all safety interlock switches are properly contacted and in good working order. Make sure the belt guard is properly secured. **NEVER** place any part of your body or clothing near the suction opening, engine, or belt guard. **SERIOUS PERSONAL INJURY COULD RESULT BY NOT FOLLOWING PROPER SAFETY PRECAUTIONS.**

**⚠️WARNING** – All safety interlock switches must be tested before each use to ensure interlock switches are in proper working order. Do not operate this machinery if interlock switches are not working correctly, lock this machine out and repair or replace interlock switch before use. **SERIOUS PERSONAL INJURY OR DEATH COULD RESULT FROM AN IMPROPERLY WORKING SAFETY INTERLOCK SWITCH.**

**⚠️WARNING** – Should the machine develop excessive vibration during operation, immediately shut the machine down and do not restart the machine until the cause of the vibration has been identified and corrected. **NOT FOLLOWING THIS PROCEDURE COULD RESULT IN SERIOUS PERSONAL INJURY.**

**⚠️WARNING** – Under no circumstances any safety interlock switch be tampered with, bypassed or disabled. Safety interlock switches maintained and in proper working order. **SERIOUS PERSONAL INJURY COULD RESULT FROM IMPROPER SAFETY INTERLOCK SWITCH MAINTENANCE.**

\*\*\*FOR WARNING/NOTICE DECALS THAT ARE MISSING OR NOT LEGIBLE, OR FOR MANUAL REPLACEMENT COPIES, OR IF YOU HAVE QUESTIONS OR CONCERNS CONTACT FORT MILLER FAB3\*\*\*  
(518)-584-4400 or [www.fmfab3.com](http://www.fmfab3.com)

**\*\*IMPORTANT SAFETY INFORMATION\*\***

**⚠WARNING** – Never disconnect any suction assembly or get near the suction case inlet opening without first completely stopping the suction impeller and shutting down and positively locking out the power source. **NOT FOLLOWING THESE PROCEDURES COULD RESULT IN SERIOUS PERSONAL INJURY.**

**⚠WARNING** – Never inspect or perform maintenance on the suction impeller without first shutting down and positively locking out the power source and be sure the suction impeller has completely stopped rotating. **NOT FOLLOWING THESE PROCEDURES COULD RESULT IN SERIOUS PERSONAL INJURY.**

**⚠WARNING** – Keep hands and feet away from the suction shroud opening and the leaf ingester mechanism at all times. Be sure the power source is shut down, positively locked out, and the impeller has completely stopped rotating before inspecting the suction shroud or leaf ingester mechanism. **NOT FOLLOWING THESE PROCEDURES COULD RESULT IN SERIOUS PERSONAL INJURY.**

**⚠WARNING** – Personnel operating this equipment should wear ear and eye protection at all times. This equipment produces high decibel noise which could damage hearing over long term exposure. As with any piece of equipment of this nature, eye protection should always be worn to protect against flying debris. **NOT FOLLOWING THESE PROCEDURES COULD RESULT IN SERIOUS PERSONAL INJURY.**

**⚠WARNING** – For all machines equipped with a hydraulically operated dumping leaf box the following procedures must be followed. No personnel is permitted on top of the machine. Machines equipped with top screening cannot support the weight of a person. Also, OSHA does not permit a person at an elevated height without the use of fall protection equipment. Prior to dumping the load it is imperative that the suction impeller has come to a complete stop. The operator(s) must be sure the machine will clear all overhead obstructions (power lines, tree limbs, etc.) prior to dumping. **NOT FOLLOWING THESE PROCEDURES COULD RESULT IN SERIOUS PERSONAL INJURY OR DEATH.**

\*\*\*FOR WARNING/NOTICE DECALS THAT ARE MISSING OR NOT LEGIBLE, OR FOR MANUAL REPLACEMENT COPIES, OR IF YOU HAVE QUESTIONS OR CONCERNS CONTACT FORT MILLER FAB3\*\*\*

(518)-584-4400 or [www.fmfab3.com](http://www.fmfab3.com)

# WINDY 400

## TABLE OF CONTENTS

Cover Page .....	1
Important Safety Information .....	2
Table of Contents .....	12
Windy 400 .....	13
Safety Switch.....	14
Emergency Stop .....	16
Front View .....	17
Light Location .....	18
Decal Location .....	20
Decal Identification .....	25

TARCO® WINDY 400

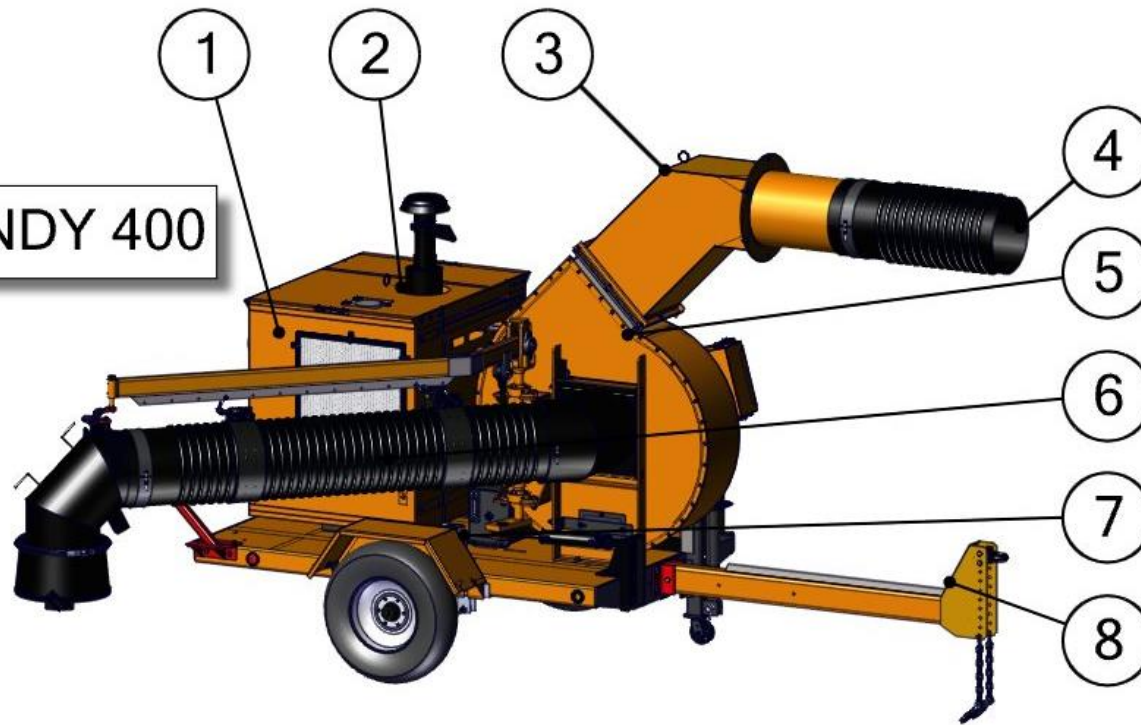

BOM ID	JDENumber (config)	Description (config)	Qty
1	33595	Engine Enclosure	1
2	46539	TARCO Windy 400	1
3	33583	DISCHARGE ELBOW 45 DEGREE	1
4	28509	Discharge Tube 16" Dia.-30"OAL	1
5	33580	45Deg Rotated Blower Housing	1

BOM ID	JDENumber (config)	Description (config)	Qty
6	33203	Suction Hose	1
7	27225	Trailer Base - TTL	1
8	28584	Drawbar Weldment	1

**⚠ WARNING** SAFETY SWITCHES NEED TO BE CHECKED FOR CORRECT OPERATION BEFORE EACH USE. DO NOT OPERATE MACHINERY WITH MALFUNCTIONING SAFETY SWITCHES. FAILURE TO COMPLY COULD RESULT IN SERIOUS PERSONAL INJURY OR DEATH.

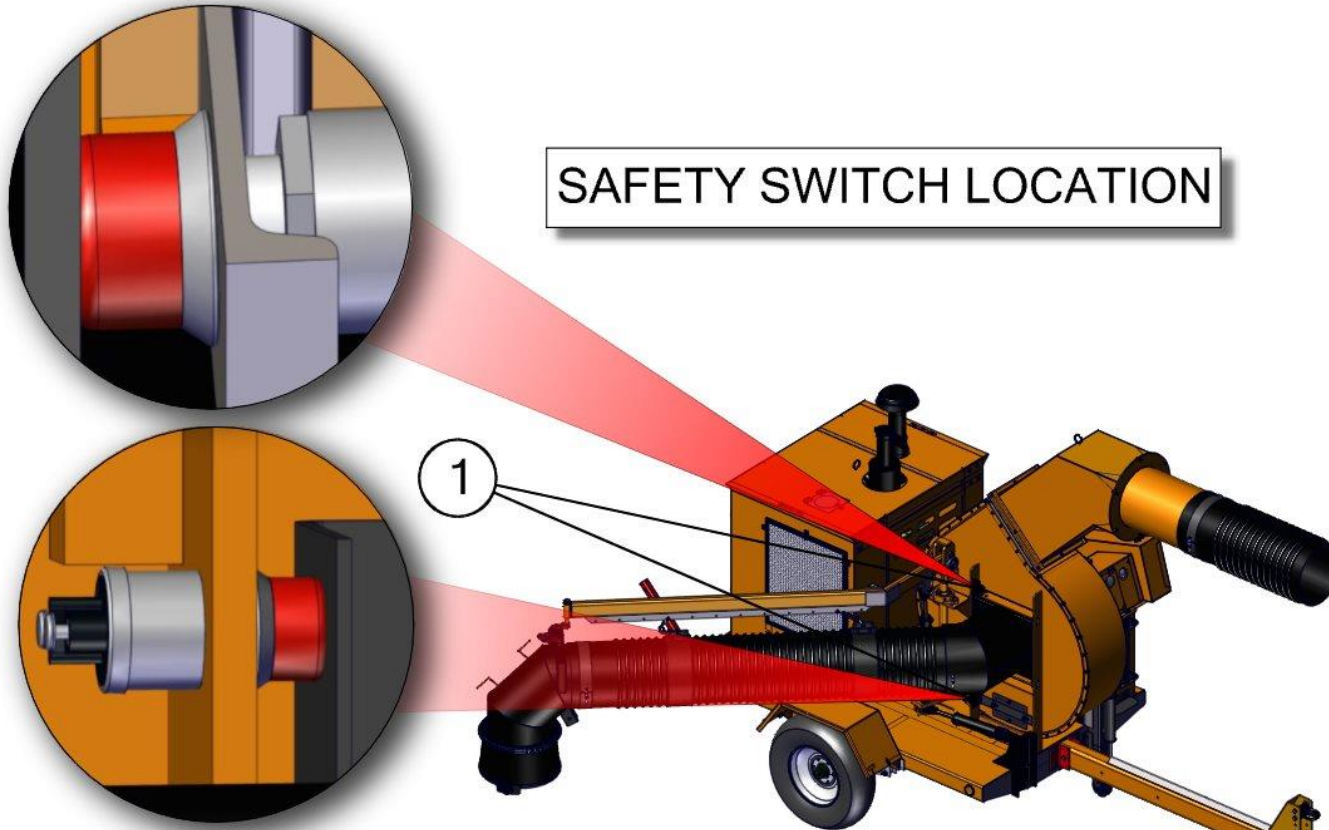

SAFETY SWITCH LOCATION

BOM ID	JDENumber (config)	Description (config)	Qty
1	32314	Switch, Safety	2

**⚠️ WARNING** SAFETY SWITCHES NEED TO BE CHECKED FOR CORRECT OPERATION BEFORE EACH USE. DO NOT OPERATE MACHINERY WITH MALFUNCTIONING SAFETY SWITCHES. FAILURE TO COMPLY COULD RESULT IN SERIOUS PERSONAL INJURY OR DEATH.

### SAFETY SWITCH LOCATION

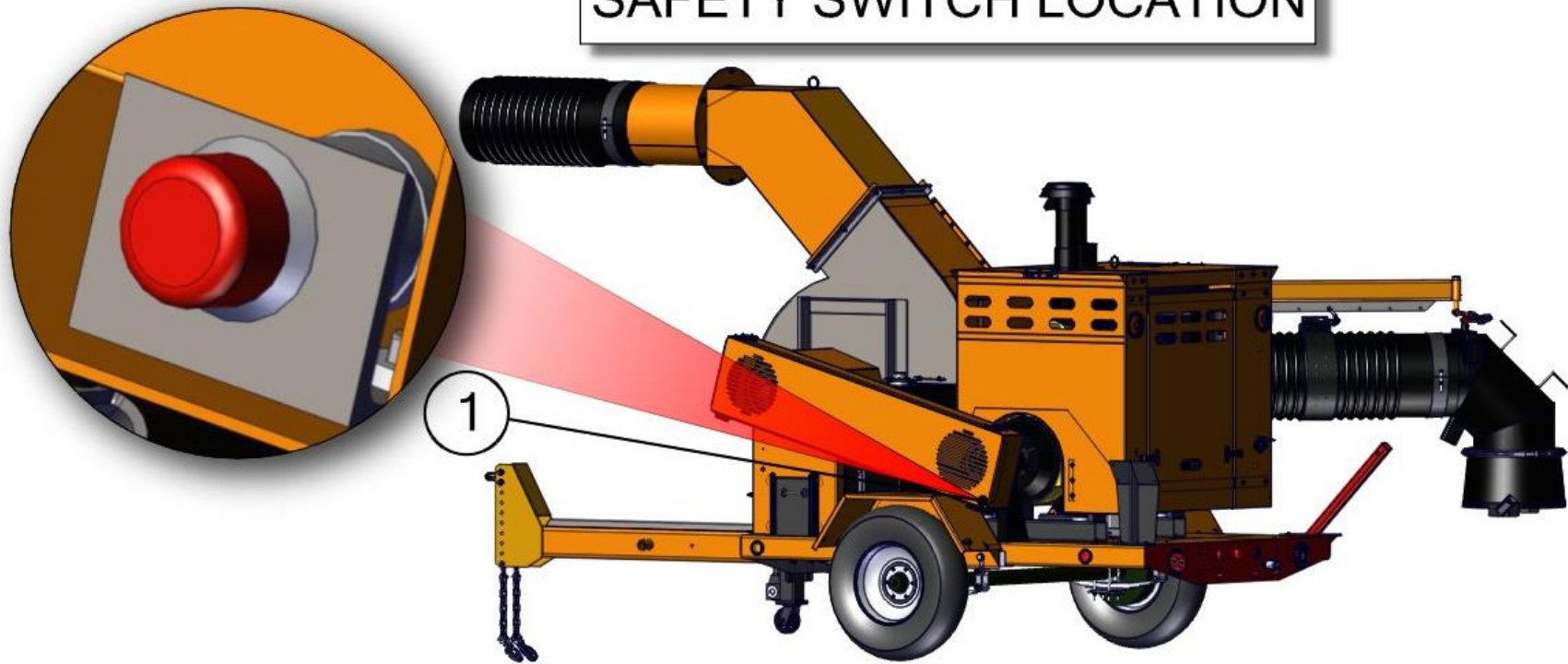

BOM ID	JDENumber (config)	Description (config)	Qty
1	32314	Switch, Safety	1

**⚠️ WARNING** EMERGENCY STOPS NEED TO BE CHECKED FOR CORRECT OPERATION BEFORE EACH USE. DO NOT OPERATE MACHINERY WITH MALFUNCTIONING EMERGENCY STOPS. FAILURE TO COMPLY COULD RESULT IN SERIOUS PERSONAL INJURY OR DEATH.

## EMERGENCY STOP

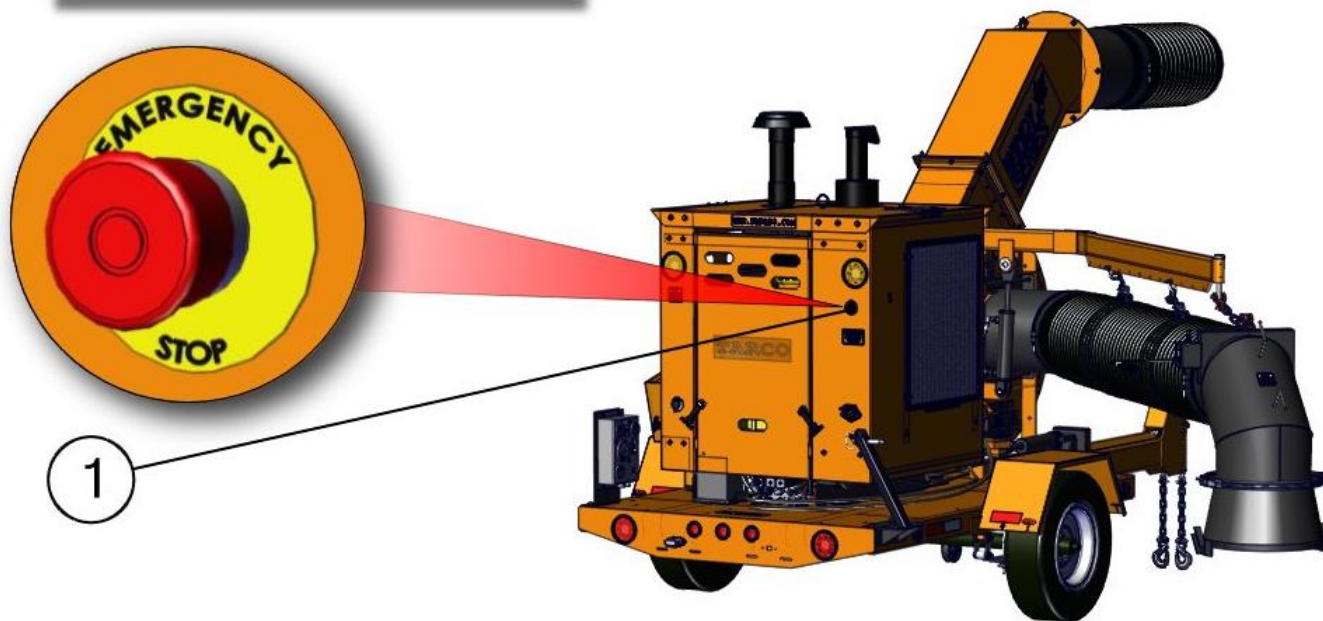

BOM ID	JDENumber (config)	Description (config)	Qty
1	33868	Mushroom Head Push Button	1



FRONT VIEW

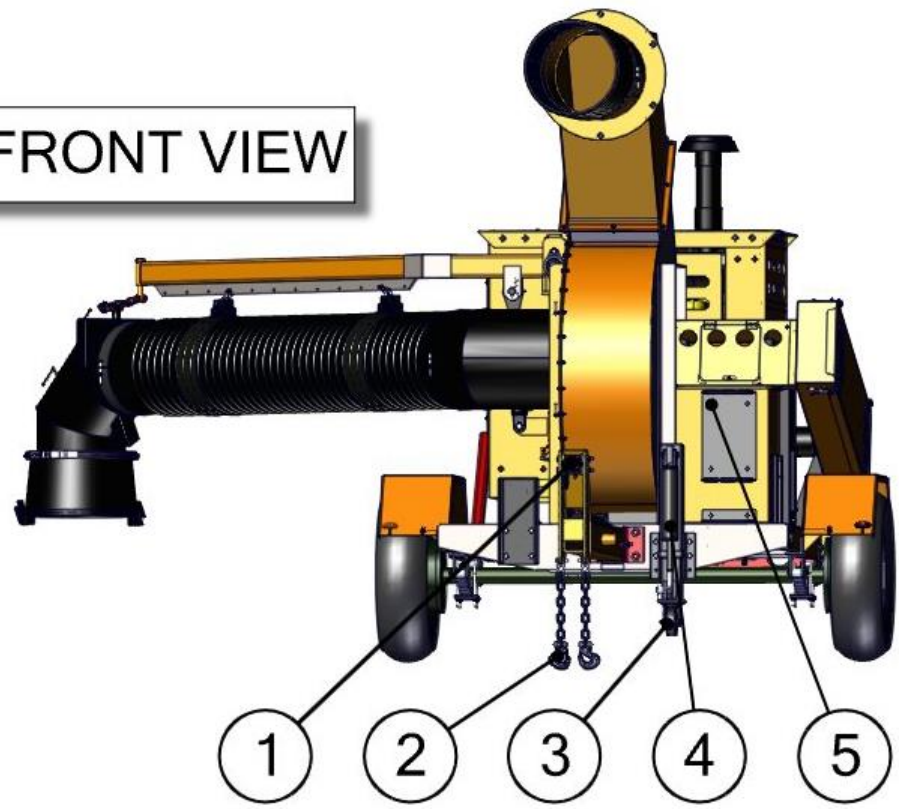

BOM ID	JDENumber (config)	Description (config)	Qty
1	27365	Pintle Eye Hitch	1
2	28254	Hook Grab 5/16" Eye Type	2
3	44218	Caster Wheel Assembly	1
4	33751	Inner Leg Assembly	1
5	33451	Tool Rack, Top	1

# LIGHTS

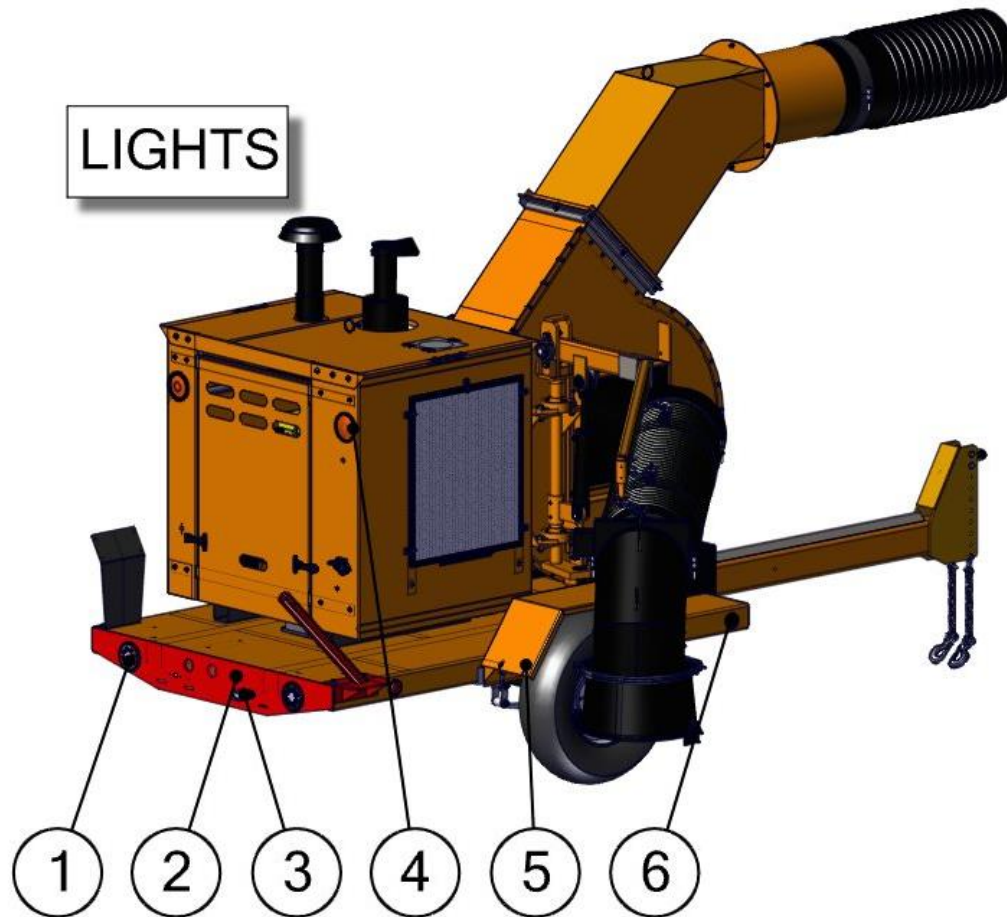

BOM ID	JDENumber (config)	Description (config)	Qty
1	32415	Stop/Turn/Tail LED Light	2
2	32824	Light, 2" LED Red	4
3	28080	Light - License Plate	1
4	33123	Light, Amber 4" Round	2
5	28026	Light Clearance - Red LED	1
6	28035	Light Clearance - 2" Amber LED	1

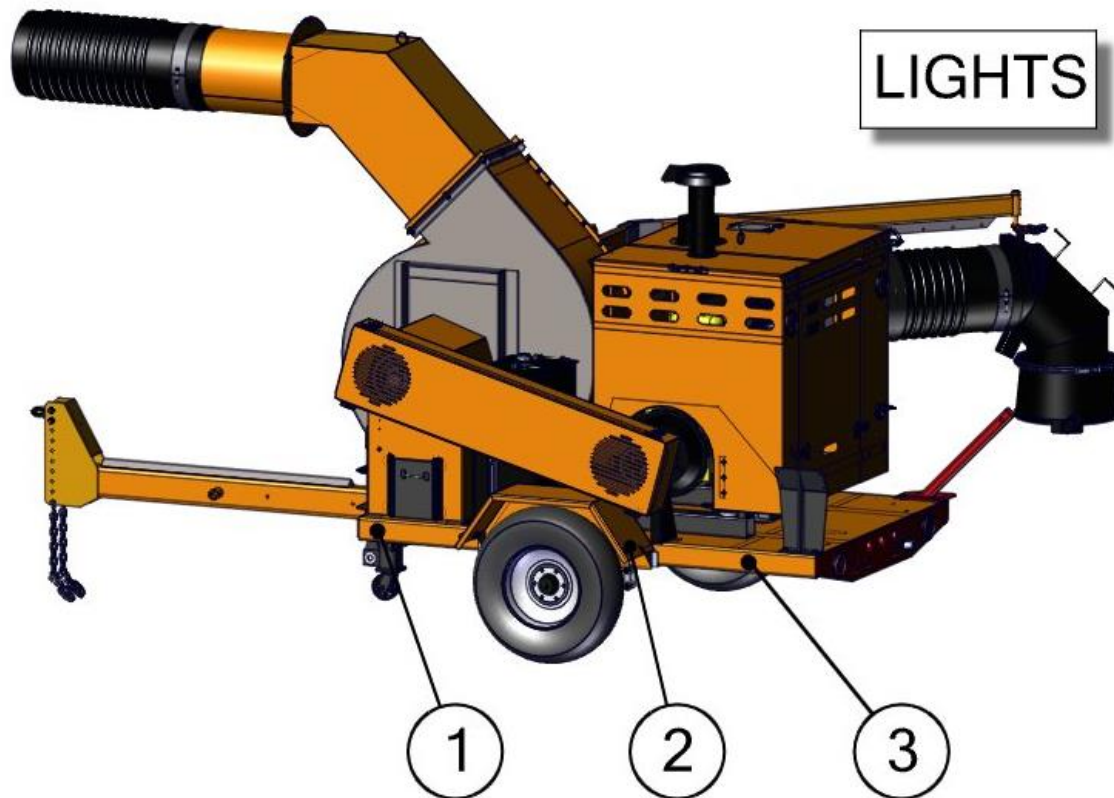

BOM ID	JDENumber (config)	Description (config)	Qty
1	28035	Light Clearance - 2" Amber LED	1
2	28026	Light Clearance - 2" Amber LED	1
3	32824	Light, 2" LED Red	1

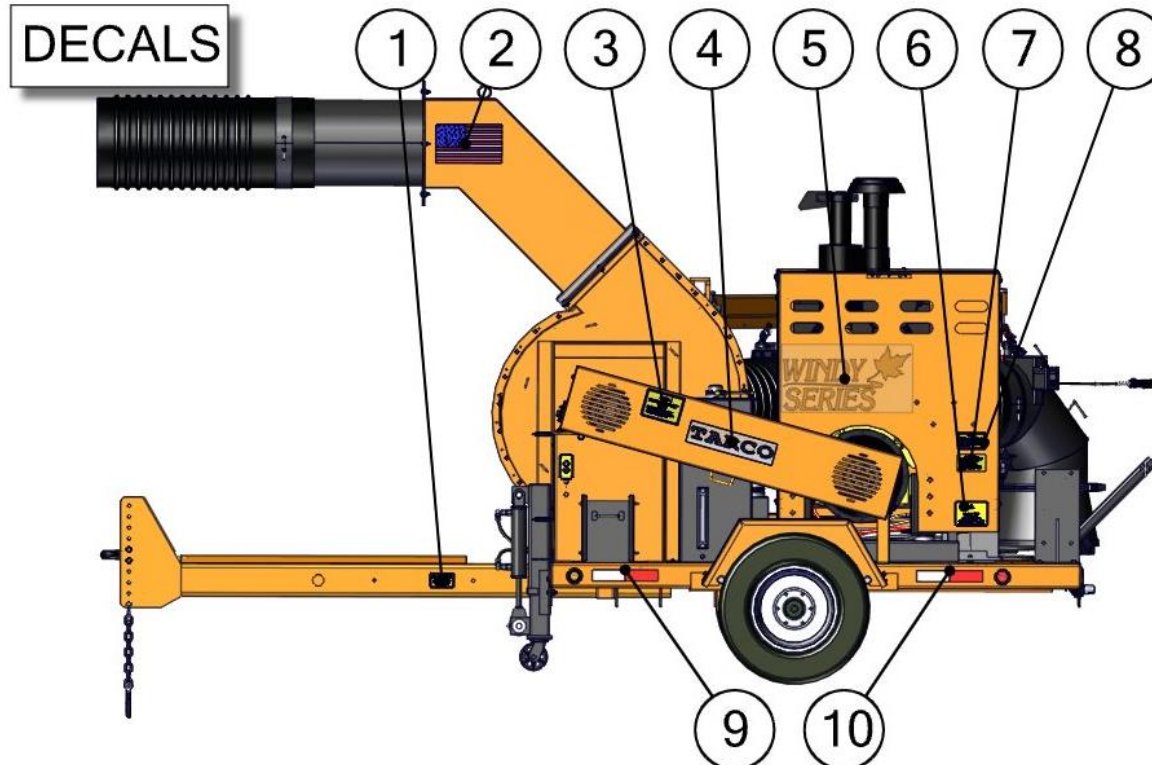

BOM ID	JDENumber (config)	Description (config)	Qty
1	27569	Decal-Warning-Failure to	1
2	27571	Decal - American Flag	1
3	27517	Decal - Caution-Read & Fully	1
4	27585	Decal - Tarco	1
5	33532	Decal "Windy Series" Black on	1
6	27713	Decal - Do Not Operate This	1

BOM ID	JDENumber (config)	Description (config)	Qty
7	27503	Decal - Mylar-Do Not Engage or	1
8	27542	Decal - Danger-Before	1
9	28318	Tape-Conspicuity 2" Wide	1
10	28318	Tape-Conspicuity 2" Wide	1

**DO NOT OPERATE EQUIPMENT IF ANY DECALS THAT CAME WITH THE PRODUCT OR WERE LATER SENT TO YOU BY FORT MILLER FAB3 ARE MISSING OR DAMAGED. THE ABOVE DIAGRAM ILLUSTRATES THE LOCATION AND NATURE OF THE WARNINGS THAT MUST BE ON THE PRODUCT: TO OBTAIN REPLACEMENT DECALS THAT ARE MISSING OR DAMAGED CONTACT FORT MILLER FAB3 AT (518)584-4400 OR WWW.FMFAB3.COM**

## DECALS

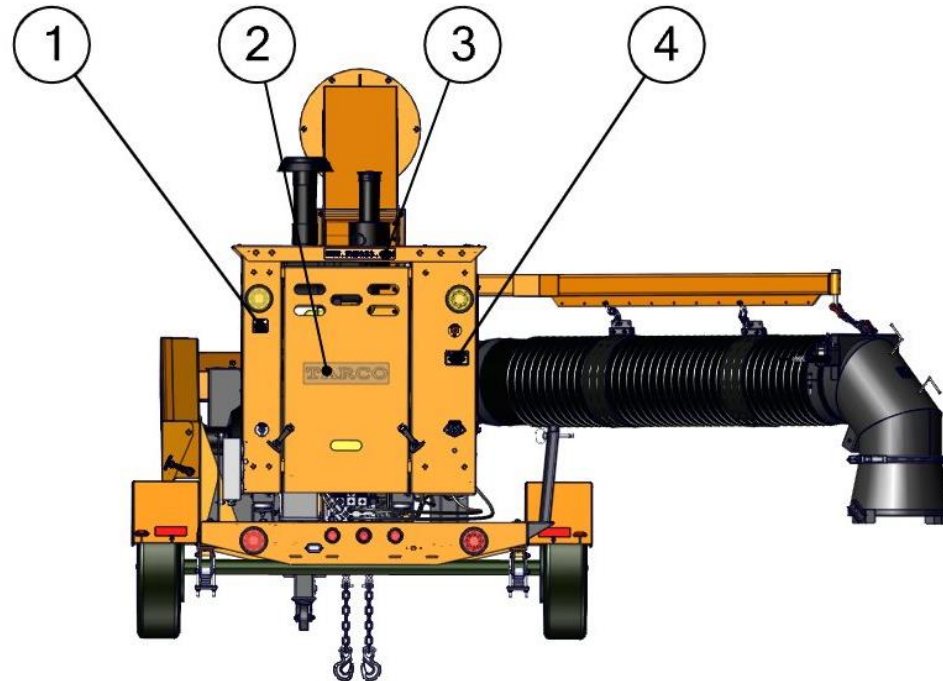

BOM ID	JDENumber (config)	Description (config)	Qty
1	27507	Decal - Safety First	1
2	27585	Decal - Tarco	1
3	29761	Decal - www.FMFAB3.COM	1
4	27569	Decal-Warning-Failure to	1

**DO NOT OPERATE EQUIPMENT IF ANY DECALS THAT CAME WITH THE PRODUCT OR WERE LATER SENT TO YOU BY FORT MILLER FAB3 ARE MISSING OR DAMAGED. THE ABOVE DIAGRAM ILLUSTRATES THE LOCATION AND NATURE OF THE WARNINGS THAT MUST BE ON THE PRODUCT: TO OBTAIN REPLACEMENT DECALS THAT ARE MISSING OR DAMAGED CONTACT FORT MILLER FAB3 AT (518)584-4400 OR WWW.FMFAB3.COM**

## DECALS

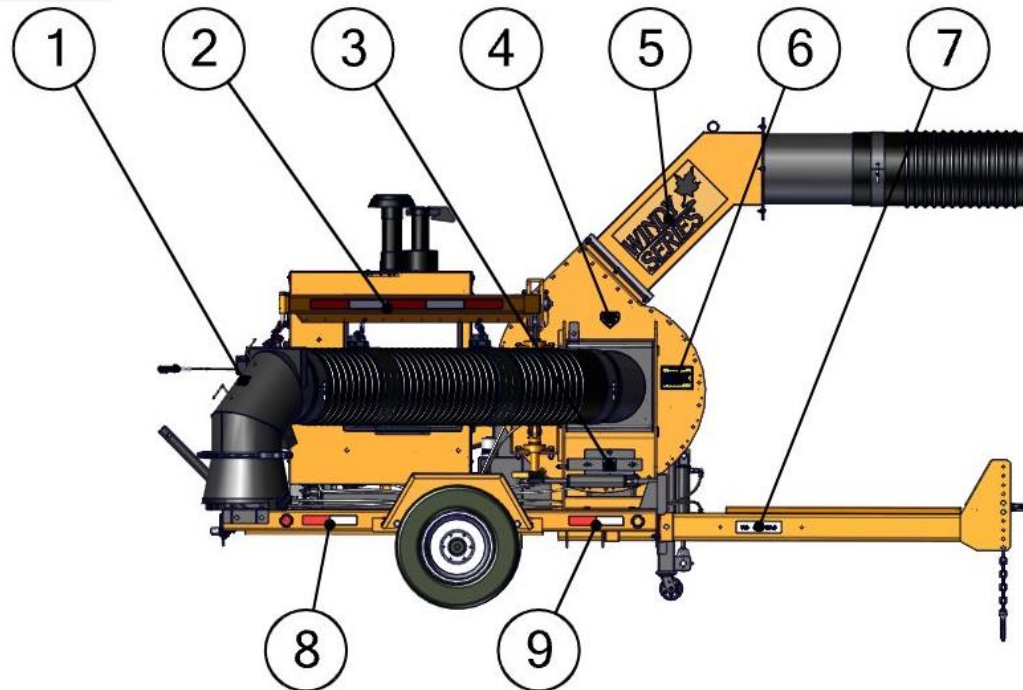

BOM ID	JDENumber (config)	Description (config)	Qty
1	27507	Decal - Safety First	1
2	28318	Tape-Conspicuity 2" Wide	1
3	27507	Decal - Safety First	1
4	27561	Decal - Danger - Keep Hand and	1
5	33532	Decal "Windy Series" Black on	1

BOM ID	JDENumber (config)	Description (config)	Qty
6	27548	Decal-Warning Danger-Do Not	1
7	27488	Decal - No Riders	1
8	28318	Tape-Conspicuity 2" Wide	1
9	28318	Tape-Conspicuity 2" Wide	1

**DO NOT OPERATE EQUIPMENT IF ANY DECALS THAT CAME WITH THE PRODUCT OR WERE LATER SENT TO YOU BY FORT MILLER FAB3 ARE MISSING OR DAMAGED. THE ABOVE DIAGRAM ILLUSTRATES THE LOCATION AND NATURE OF THE WARNINGS THAT MUST BE ON THE PRODUCT: TO OBTAIN REPLACEMENT DECALS THAT ARE MISSING OR DAMAGED CONTACT FORT MILLER FAB3 AT (518)584-4400 OR WWW.FMFAB3.COM**

**DECALS**

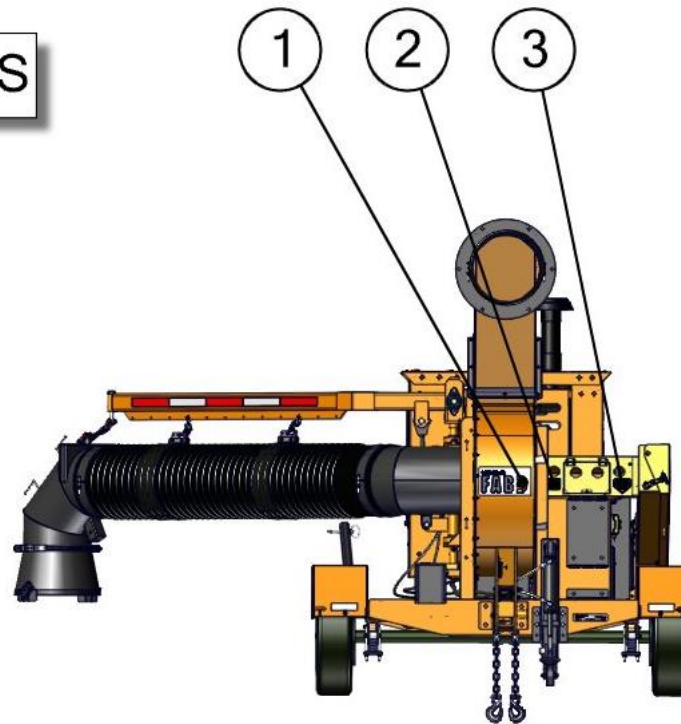

BOM ID	JDENumber (config)	Description (config)	Qty
1	29759	Decal - FMFAB3	1
2	27507	Decal - Safety First	1
3	27561	Decal - Danger - Keep Hand and	1

**DO NOT OPERATE EQUIPMENT IF ANY DECALS THAT CAME WITH THE PRODUCT OR WERE LATER SENT TO YOU BY FORT MILLER FAB3 ARE MISSING OR DAMAGED. THE ABOVE DIAGRAM ILLUSTRATES THE LOCATION AND NATURE OF THE WARNINGS THAT MUST BE ON THE PRODUCT: TO OBTAIN REPLACEMENT DECALS THAT ARE MISSING OR DAMAGED CONTACT FORT MILLER FAB3 AT (518)584-4400 OR WWW.FMFAB3.COM**

## DECALS

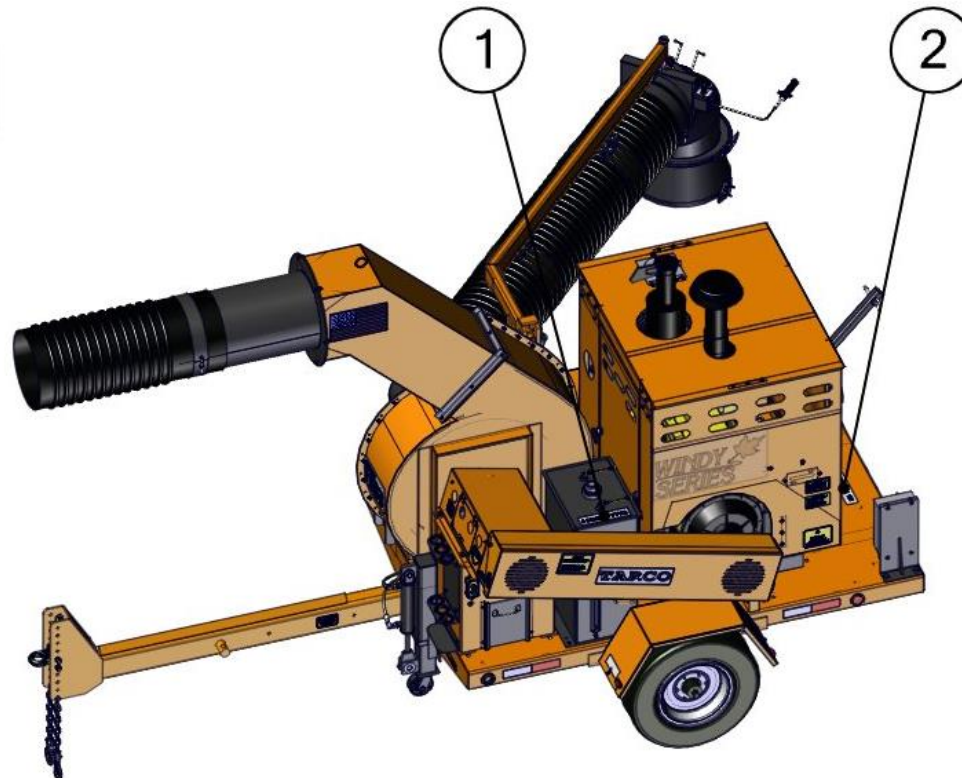

BOM ID	JDENumber (config)	Description (config)	Qty
1	27578	Decal - Diesel Fuel	1
2	27488	Decal - No Riders	1

**DO NOT OPERATE EQUIPMENT IF ANY DECALS THAT CAME WITH THE PRODUCT OR WERE LATER SENT TO YOU BY FORT MILLER FAB3 ARE MISSING OR DAMAGED. THE ABOVE DIAGRAM ILLUSTRATES THE LOCATION AND NATURE OF THE WARNINGS THAT MUST BE ON THE PRODUCT: TO OBTAIN REPLACEMENT DECALS THAT ARE MISSING OR DAMAGED CONTACT FORT MILLER FAB3 AT (518)584-4400 OR WWW.FMFAB3.COM**



# DECAL IDENTIFICATION

## NOTICE

DO NOT ENGAGE OR DISENGAGE CLUTCH IF ENGINE EXCEEDS 800 - 1000 R.P.M  
FREQUENT INITIAL CLUTCH ADJUSTMENTS ARE NECESSARY.  
(SEE CLUTCH PTO INSTRUCTION BOOK FURNISHED WITH ENGINE.)

JDE# 27503 (7500-34) QTY=1

## WARNING

### SAFETY FIRST

1. KEEP ALL SHIELDS IN PLACE.
2. STOP MACHINE TO ADJUST & OIL
3. WHEN MECHANISM BECOMES CLOGGED, DISCONNECT POWER BEFORE CLEANING
4. KEEP HANDS, FEET AND CLOTHING AWAY FROM POWER DRIVEN PARTS

IF NOT AVOIDED, COULD RESULT IN DEATH OR SERIOUS INJURY.

JDE# 27507 (7500-36) QTY=4

## NOTICE

**MACHINE DAMAGE WILL RESULT IF NOT FOLLOWED**

LOCATION DETAIL SEE PAGE 20 ITEM 7

## WARNING

**IF NOT FOLLOWED SEVERE INJURY, DEATH OR EQUIPMENT DAMAGE COULD RESULT**

LOCATION DETAIL SEE PAGE 21 ITEM 1

LOCATION DETAIL SEE PAGE 22 ITEM 1

LOCATION DETAIL SEE PAGE 22 ITEM 3

LOCATION DETAIL SEE PAGE 23 ITEM 2



JDE# 27542 (7500-43) QTY=1



JDE# 27548 (7500-46) QTY=1





JDE# 27561 (7500-87) QTY=2



JDE# 27569 (7500-89) QTY=2



**DIESEL FUEL**

JDE# 27578 (7500-92) QTY=1

**TARCO**

JDE# 27585 (7500-94) QTY=2



JDE# 27713 (7500-98) QTY=1

**NOTICE**

**MACHINE DAMAGE WILL RESULT IF  
NOT FOLLOWED**

LOCATION DETAIL SEE PAGE 24 ITEM 1

**COMPANY BRAND**

LOCATION DETAIL SEE PAGE 20 ITEM 4

LOCATION DETAIL SEE PAGE 21 ITEM 2



**IF NOT FOLLOWED SEVERE INJURY, DEATH  
OR EQUIPMENT DAMAGE COULD RESULT**

LOCATION DETAIL SEE PAGE 20 ITEM 6



JDE# 27488 (7500-102) QTY=2



JDE# 29761 (7500-101) QTY=1



JDE# 27517 (7500-41) QTY=1



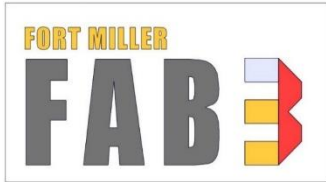

JDE# 29759 (7500-1) QTY=1

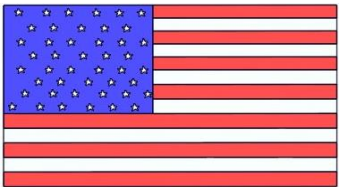

JDE# 27571 (7500-90) QTY=1



JDE# 33532 (33532) QTY=2

**COMPANY LOGO**

LOCATION DETAIL SEE PAGE 23 ITEM 1

**MADE IN THE USA**

LOCATION DETAIL SEE PAGE 20 ITEM 2

**MACHINE NAME**

LOCATION DETAIL SEE PAGE 20 ITEM 5

LOCATION DETAIL SEE PAGE 22 ITEM 5



JDE# 28318 (60033-56) QTY=132”

 **CAUTION**

**USE CAUTION POTENTIAL HAZARD**

LOCATION DETAIL SEE PAGE 20 ITEM 9

LOCATION DETAIL SEE PAGE 20 ITEM 10

LOCATION DETAIL SEE PAGE 22 ITEM 2

LOCATION DETAIL SEE PAGE 22 ITEM 8

LOCATION DETAIL SEE PAGE 22 ITEM 9