

****KEEP THIS MANUAL****

**TARCOO® TYPHOON
SAFETY MANUAL**

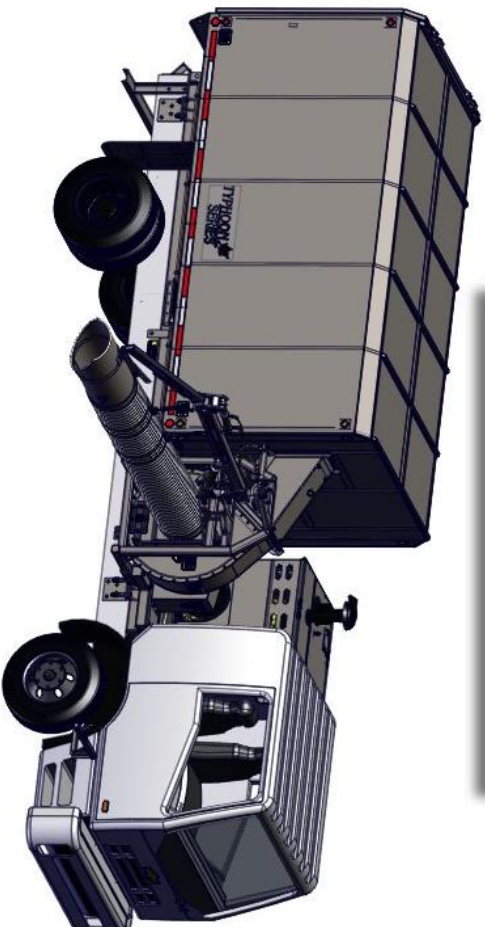

FORT MILLER
FAB3

FORT MILLER FAB3 CORP.
678 WILBUR AVE.
GREENWICH, NY 12834
www.fmfab3.com
TEL. 518-584-4400
FAX. 518-584-6630

 **WARNING**

Read and understand operator's manual before using this equipment.

Failure to follow operating instructions could result in death or serious injury.

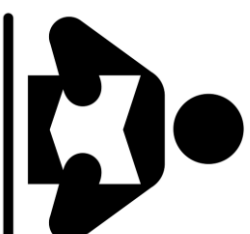

****IMPORTANT SAFETY INFORMATION****



Thank you and congratulations on your recent purchase.
Please take time reading and understanding the manual before operating the equipment.
Fill in the following information, so that it is at hand when needed.

MODEL _____
SERIAL NO. _____
DATE OF PURCHASE _____



*****The operator must carefully read and follow any warnings, safety sign and instructions provided with or located on the equipment. *****

*****Please keep a copy of the manual in the cab so that it may be consulted by the operator. *****





*****Do not allow untrained operators to use this equipment as serious injury, death or equipment damage could result. *****

FOR WARNING/NOTICE DECALS THAT ARE MISSING OR NOT LEGIBLE, OR FOR MANUAL REPLACEMENT COPIES, OR IF YOU HAVE QUESTIONS OR CONCERNS CONTACT FORT MILLER FAB3
(518)-584-4400 or www.fmfab3.com

****IMPORTANT SAFETY INFORMATION****

SIGNAL WORDS & DEFINITIONS

SYMBOLS USED IN THE MANUAL AND ON THE MACHINERY

	SAFETY ALERT SYMBOL USED TO ALERT OF POTENTIAL PERSONAL INJURY HAZARDS. OBEY ALL SAFETY MESSAGES THAT FOLLOW THIS SYMBOL TO AVOID POSSIBLE INJURY OR DEATH.
 DANGER	DANGER INDICATES A HAZARDOUS SITUATION WHICH, IF NOT AVOIDED, WILL RESULT IN DEATH OR SERIOUS INJURY.
 WARNING	WARNING INDICATES A HAZARDOUS SITUATION WHICH, IF NOT AVOIDED, COULD RESULT IN DEATH OR SERIOUS INJURY.
 CAUTION	CAUTION USED WITH THE SAFETY ALERT SYMBOL, INDICATES A HAZARDOUS SITUATION WHICH, IF NOT AVOIDED, COULD RESULT IN MINOR OR MODERATE INJURY.
NOTICE	NOTICE IS USED TO ADDRESS PRACTICES NOT RELATED TO PERSONAL INJURY.

*****FOR WARNING/NOTICE DECALS THAT ARE MISSING OR NOT LEGIBLE, OR FOR MANUAL REPLACEMENT COPIES, OR IF YOU HAVE QUESTIONS OR CONCERNS CONTACT FORT MILLER FAB3*****

(518)-584-4400 or www.fmfab3.com

****IMPORTANT SAFETY INFORMATION****



A WARNING SYMBOL INDICATES A HAZARDOUS SITUATION WHICH, IF NOT AVOIDED, COULD RESULT IN SERIOUS INJURY OR DEATH.

- **⚠ WARNING** DO NOT OPERATE MACHINERY WITHOUT READING AND UNDERSTANDING THIS MANUAL. **FAILURE TO FOLLOW THIS INFORMATION CAN LEAD TO MACHINE DAMAGE, SERIOUS INJURY, OR EVEN DEATH.**
- **⚠ WARNING** USE ALL MACHINERY FOR ITS INTENDED USE. **FAILURE TO FOLLOW THIS INFORMATION CAN LEAD TO MACHINE DAMAGE, SERIOUS INJURY, OR EVEN DEATH.**
- **⚠ WARNING** DO NOT MODIFY EQUIPMENT. **FAILURE TO FOLLOW THIS INFORMATION CAN LEAD TO MACHINE DAMAGE, SERIOUS INJURY, OR EVEN DEATH.**
- **⚠ WARNING** ANY MISS USE OR MODIFICATION TO THE EQUIPMENT **CAN LEAD TO MACHINE DAMAGE, SERIOUS INJURY, OR EVEN DEATH.**
- **⚠ WARNING** DO NOT RIDE ON MACHINERY. **FAILURE TO FOLLOW THIS INFORMATION CAN LEAD TO MACHINE DAMAGE, SERIOUS INJURY, OR EVEN DEATH.**

FOR WARNING/NOTICE DECALS THAT ARE MISSING OR NOT LEGIBLE, OR FOR MANUAL REPLACEMENT COPIES, OR IF YOU HAVE QUESTIONS OR CONCERNS CONTACT FORT MILLER FAB3
(518)-584-4400 or www.fmfab3.com

****IMPORTANT SAFETY INFORMATION****

IMPORTANT SAFETY INFORMATION

TO THE OPERATOR

Prior to using the TARCO® TYPHOON, you must be properly trained in the full operation of this machine. This would include but not be limited to a complete review of the operating and safety manual and a complete understanding of all safety procedures including the safety decals and information on this machine. If there is something you do not understand, ask your supervisor to explain it to you. If you require additional manuals or decals, please contact your dealer or the manufacturer.

Make sure all the manufacturers' protective guards, shields, and screens are in good repair, in place, and securely fastened. Damaged, missing, or weakened safety components can create a hazardous situation for the operator. NEVER remove or modify any safety components on this equipment.

Wear all the protective clothing and personal safety devices issued to you or called for by the job conditions. This may include but is not limited to a hard hat, safety shoes, safety glasses or goggles, heavy gloves, hearing protection, reflective clothing or wet weather gear. Remember, you are responsible for your safety and that of your co-workers. Good safety practices protect you and the people around you.

NEVER ride on any part of the equipment or trailer when operating the machine or at any time. Never modify the machine for riders in any way. Prior to operating this machine, be certain that all operators can ride safely in the truck or vehicle being used to trailer the machine. If your machine has been altered to accommodate riders, remove these alterations immediately as this can result in serious injury or death. A "NO RIDERS" decal should be in place. Please request these from your dealer or use the web to contact and request them from Fort Miller FAB3 Corp. (518)-584-4400 or www.fmfab3.com.

****IMPORTANT SAFETY INFORMATION****



A WARNING SYMBOL INDICATES A HAZARDOUS SITUATION WHICH, IF NOT AVOIDED, COULD RESULT IN SERIOUS INJURY OR DEATH



⚠ WARNING DO NOT operate unit without wearing proper safety equipment as described in this manual.

⚠ WARNING DO NOT operate, maintain or repair this unit without fully reading and understanding ALL aspects of this manual.

⚠ WARNING DO NOT lubricate, make any adjustment or repairs before proper LOCK OUT/TAG OUT is performed.

⚠ WARNING DO NOT operate the unit while under the influence of alcohol, drugs, or any medication that could impair operating abilities.

⚠ WARNING DO NOT operate the unit with ANY guards or safety devices broken, missing, or inoperable.

⚠ WARNING DO NOT operate the unit without fully inspecting the unit for any damage or leakage.

⚠ WARNING DO NOT use equipment that is not safe.

⚠ WARNING DO NOT operate the unit if all operating controls and safety devices are not in good working order.

⚠ WARNING DO NOT operate unit in a state of disrepair.

⚠ WARNING DO NOT ride, sit or stand on the unit while in use.

⚠ WARNING DO NOT place hands or feet near moving or rotating parts.

FOR WARNING/NOTICE DECALS THAT ARE MISSING OR NOT LEGIBLE, OR FOR MANUAL REPLACEMENT COPIES, OR IF YOU HAVE QUESTIONS OR CONCERNS CONTACT FORT MILLER FAB3

(518)-584-4400 or www.fmfab3.com

****IMPORTANT SAFETY INFORMATION****

- ⚠ WARNING** DO NOT jump from the vehicle.
- ⚠ WARNING** DO NOT allow personnel to ride anywhere, except in the cab, when the unit or vehicle is in operation.
- ⚠ WARNING** DO NOT modify the unit for any reason to allow for riders.
- ⚠ WARNING** DO NOT exceed weight limitations.
- ⚠ WARNING** DO NOT smoke or weld near the unit.
- ⚠ WARNING** DO NOT leave machine running unattended.
- ⚠ WARNING** DO NOT park unit on a steep grade or slope.
- ⚠ WARNING** DO NOT operate the unit until all hydraulic components are checked for leaks and damage, and repaired if found.
- ⚠ WARNING** DO NOT fill the fuel tank with the engine running. Allow engine to cool before refueling.
- ⚠ WARNING** DO NOT operate the unit if fuel is spilled or with cap off.
- ⚠ WARNING** DO NOT run the engine in an enclosed area.
- ⚠ WARNING** DO NOT operate engine with an accumulation of combustible material on or around the engine.
- ⚠ WARNING** DO NOT run engine with air cleaner removed.
- ⚠ WARNING** DO NOT operate the unit if there is excessive vibration, shut down and repair immediately.

FOR WARNING/NOTICE DECALS THAT ARE MISSING OR NOT LEGIBLE, OR FOR MANUAL REPLACEMENT COPIES, OR IF YOU HAVE QUESTIONS OR CONCERNS CONTACT FORT MILLER FAB3
(518)-584-4400 or www.fmfab3.com

****IMPORTANT SAFETY INFORMATION****

⚠ WARNING

A WARNING SYMBOL INDICATES A HAZARDOUS SITUATION WHICH, IF NOT AVOIDED, COULD RESULT IN SERIOUS INJURY OR DEATH

- ⚠ WARNING** DO wear proper safety equipment as described in this manual.
- ⚠ WARNING** DO fully read and understand the owner's manual before operating, maintaining, or repairing this equipment.
- ⚠ WARNING** DO preform proper LOCK OUT/TAG OUT before any adjustment or repairs are made.
- ⚠ WARNING** DO remove the negative battery cable before doing any maintenance on the unit.
- ⚠ WARNING** DO follow and obey ALL safety regulations.
- ⚠ WARNING** DO replace any worn or missing safety decals immediately contact: (518)584-4400 or at www.fmfab3.com
- ⚠ WARNING** DO completely inspect the unit before leaving the service garage.
- ⚠ WARNING** DO watch for pedestrians, animals, and other foreign objects when operating this unit.
- ⚠ WARNING** DO check the impeller, liners and blower housing for cracks and holes daily. Replace if necessary.
- ⚠ WARNING** DO watch for pedestrians, animals and other foreign material while vacuuming leaves.
- ⚠ WARNING** DO wear proper safety equipment as described in this manual.
- ⚠ WARNING** DO inspect and be attentive to what is being vacuumed.
- ⚠ WARNING** DO follow engine manufactures operating and maintenance instructions.
- ⚠ WARNING** DO check fuel lines and fittings frequently for cracks or leaks. Replace if necessary.

*****FOR WARNING/NOTICE DECALS THAT ARE MISSING OR NOT LEGIBLE, OR FOR MANUAL REPLACEMENT COPIES, OR IF YOU HAVE QUESTIONS OR CONCERNS CONTACT FORT MILLER FAB3*****

(518)-584-4400 or www.fmfab3.com

****IMPORTANT SAFETY INFORMATION****



A WARNING SYMBOL INDICATES A HAZARDOUS SITUATION WHICH, IF NOT AVOIDED, COULD RESULT IN SERIOUS INJURY OR DEATH

⚠️ WARNING – Before starting the engine or applying power to the machine be sure the suction assembly is securely in place over the suction and discharge openings and ready for operation. Make sure all safety interlock switches are properly contacted and in good working order. Make sure the belt guard is properly secured. **NEVER** place any part of your body or clothing near the suction opening, engine, or belt guard. **SERIOUS PERSONAL INJURY OR DEATH COULD RESULT BY NOT FOLLOWING PROPER SAFETY PRECAUTIONS.**

⚠️ WARNING – All safety interlock switches must be tested before each use to ensure interlock switches are in proper working order. Do not operate this machinery if interlock switches are not working correctly, lock this machine out and repair or replace interlock switch before use. **SERIOUS PERSONAL INJURY OR DEATH COULD RESULT FROM AN IMPROPERLY WORKING SAFETY INTERLOCK SWITCH.**

⚠️ WARNING – Should the machine develop excessive vibration during operation, immediately shut the machine down and do not restart the machine until the cause of the vibration has been identified and corrected. **NOT FOLLOWING THIS PROCEDURE COULD RESULT IN SERIOUS PERSONAL INJURY OR DEATH.**

⚠️ WARNING – Under no circumstances any safety interlock switch be tampered with, bypassed or disabled. ALL Safety interlock switches are to be maintained and in proper working order. **SERIOUS PERSONAL INJURY OR DEATH COULD RESULT FROM IMPROPER SAFETY INTERLOCK SWITCH MAINTENANCE.**

FOR WARNING/NOTICE DECALS THAT ARE MISSING OR NOT LEGIBLE, OR FOR MANUAL REPLACEMENT COPIES, OR IF YOU HAVE QUESTIONS OR CONCERNS CONTACT FORT MILLER FAB3
(518)-584-4400 or www.fmfab3.com

****IMPORTANT SAFETY INFORMATION****

⚠️WARNING – Never disconnect any suction assembly or get near the suction case inlet opening without first completely stopping the suction impeller, shutting down and positively locking out the power source. **NOT FOLLOWING THESE PROCEDURES COULD RESULT IN SERIOUS PERSONAL INJURY OR DEATH.**

⚠️WARNING – Never inspect or perform maintenance on the suction impeller without first shutting down and positively locking out the power source and be sure the suction impeller has completely stopped rotating. **NOT FOLLOWING THESE PROCEDURES COULD RESULT IN SERIOUS PERSONAL INJURY OR DEATH.**

⚠️WARNING – Keep hands and feet away from the suction shroud opening and the leaf ingester mechanism at all times. Be sure the power source is shut down, positively locked out, and the impeller has completely stopped rotating before inspecting the suction shroud or leaf ingester mechanism. **NOT FOLLOWING THESE PROCEDURES COULD RESULT IN SERIOUS PERSONAL INJURY OR DEATH.**

⚠️WARNING – Personnel operating this equipment should wear ear and eye protection at all times. This equipment produces high decibel noise which could damage hearing over long term exposure. As with any piece of equipment of this nature, eye protection should always be worn to protect against flying debris. **NOT FOLLOWING THESE PROCEDURES COULD RESULT IN SERIOUS PERSONAL INJURY OR DEATH.**

⚠️WARNING – For all machines equipped with a hydraulically operated dumping leaf box the following procedures must be followed. No personnel is permitted on top of the machine. Machines equipped with top screening cannot support the weight of a person. Also, OSHA does not permit a person at an elevated height without the use of fall protection equipment. Prior to dumping the load it is imperative that the suction impeller has come to a complete stop. The operator(s) must be sure the machine will clear all overhead obstructions (power lines, tree limbs, etc.) prior to dumping. **NOT FOLLOWING THESE PROCEDURES COULD RESULT IN SERIOUS PERSONAL INJURY OR DEATH.**

FOR WARNING/NOTICE DECALS THAT ARE MISSING OR NOT LEGIBLE, OR FOR MANUAL REPLACEMENT COPIES, OR IF YOU HAVE QUESTIONS OR CONCERNS CONTACT FORT MILLER FAB3
(518)-584-4400 or www.fmfab3.com

****IMPORTANT SAFETY INFORMATION****

CAUSES OF A EQUIPMENT ROLL OVER



A WARNING SYMBOL INDICATES A HAZARDOUS SITUATION WHICH, IF NOT AVOIDED, COULD RESULT IN SERIOUS INJURY OR DEATH



WARNING Never dump or drive equipment on uneven ground.



WARNING Keep dump body free of material build up, that can result in an unbalanced load.



WARNING Material should be centered in the dump body while loading, before being transported, or dumped.



WARNING Ensure equipment is in good working condition before each use.



WARNING The inside of the dump body should be smooth and free of holes.



WARNING Material can freeze in the winter if stored in the dump body causing load to be unbalanced.



WARNING Ensure the tailgate is unlatched before raising the dump body.



WARNING Allow truck to move forward slightly while dumping.



WARNING Immediately lower dump body if any leaning occurs during the dumping process.



WARNING No one should be beside of the truck while dumping.



WARNING Watch for obstacles above the truck including but not limited to utility wires and branches.



WARNING Always stay alert and pay close attention to the surrounding area while driving or operating this equipment.

*****FOR WARNING/NOTICE DECALS THAT ARE MISSING OR NOT LEGIBLE, OR FOR MANUAL REPLACEMENT COPIES, OR IF YOU HAVE QUESTIONS OR CONCERNS CONTACT FORT MILLER FAB3*****

(518)-584-4400 or www.fmfab3.com

TYPHOON

TABLE OF CONTENTS

Cover Page.....	1
Important Safety Information	2
Table of Contents	12
Typhoon	13
Master Disconnect	14
Safety Switch	15
Body Prop	16
Light Location	17
Cab Controls Location.....	20
Decal Location	22
Decal Identification	27

TARCO® TYPHOON

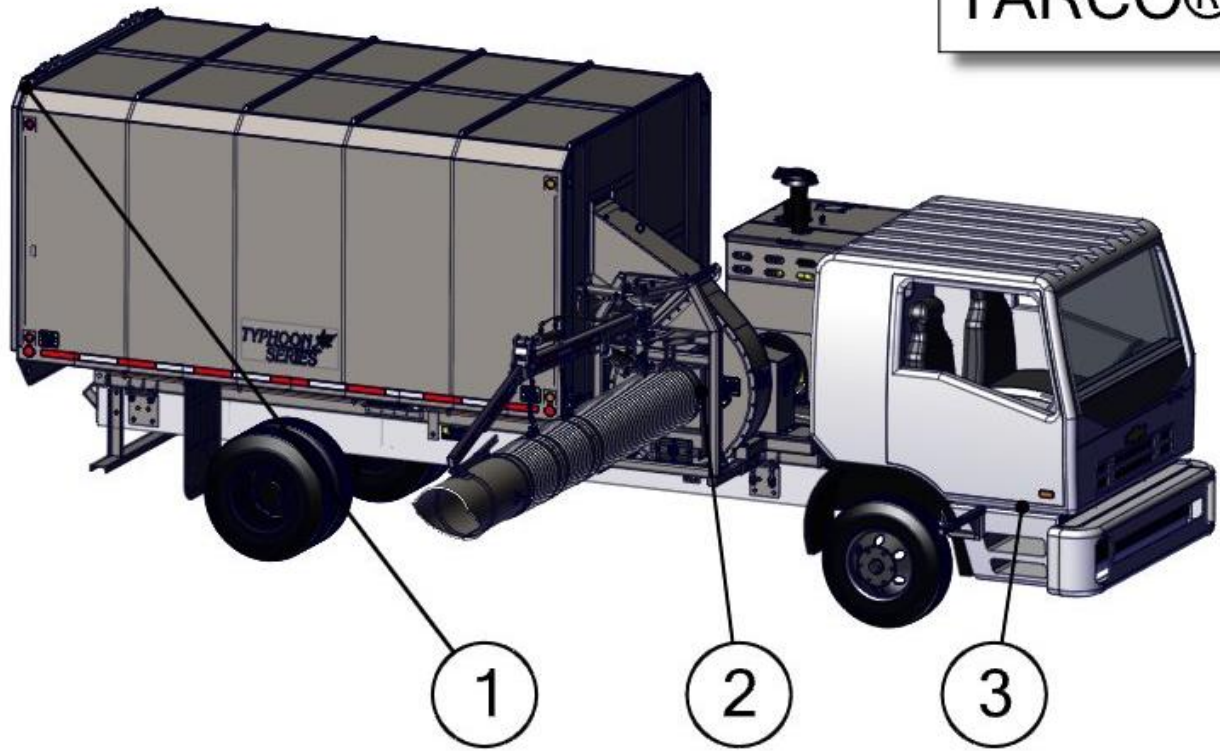

BOM ID	Description (config)	Qty
1	LEAF COLLECTION BOX	1
2	SUCTION HOUSING & ENGINE	1
3	TRUCK-FREIGHTLINER M2-106	1

TARCO® TYPHOON MASTER DISCONNECT

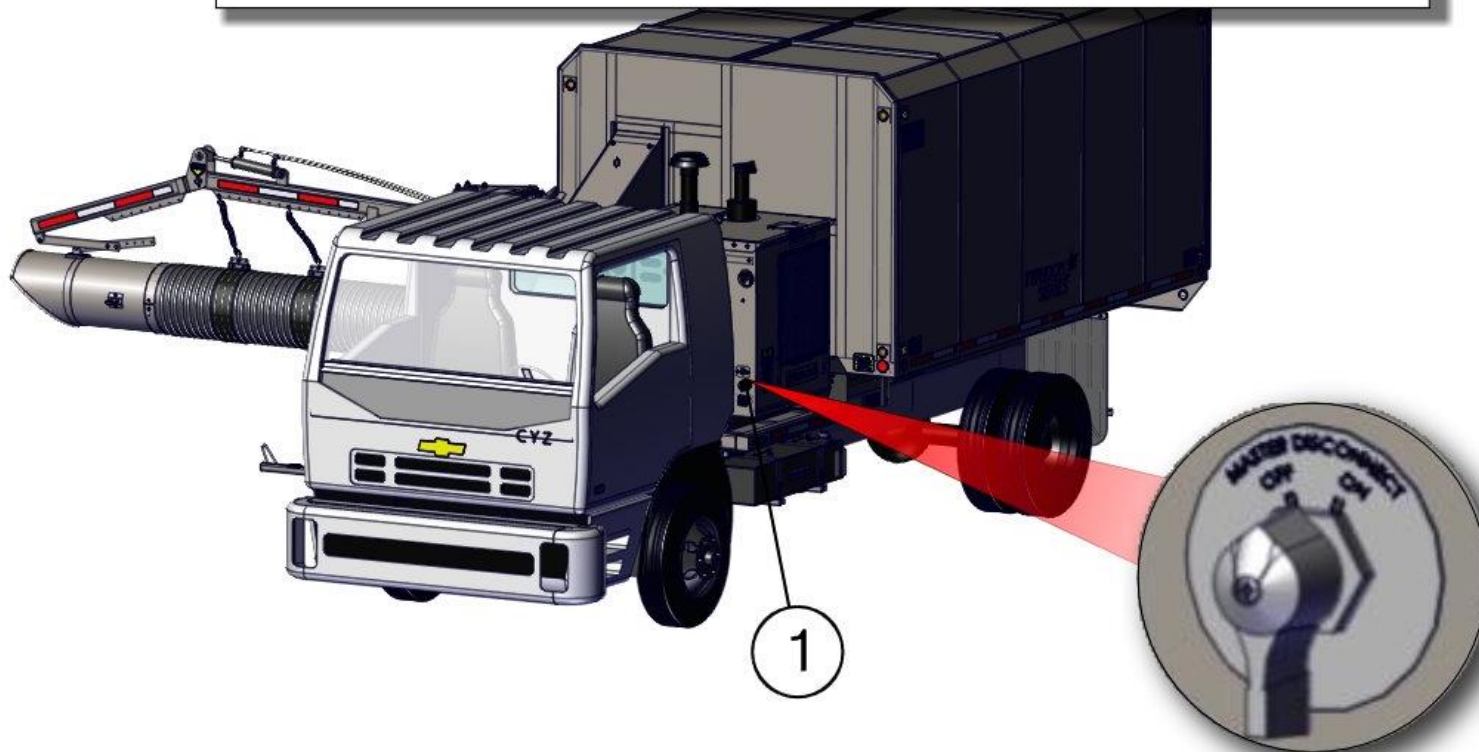

BOM ID	JDENumber (config)	Description (config)	Qty
1	37001	Battery Master Disconnect	1

⚠️ WARNING SAFETY SWITCHES NEED TO BE CHECKED FOR CORRECT OPERATION BEFORE EACH USE. DO NOT OPERATE MACHINERY WITH MALFUNCTIONING SAFETY SWITCHES. FAILURE TO COMPLY COULD RESULT IN SERIOUS PERSONAL INJURY OR DEATH.

TARCO® TYPHOON SAFETY SWITCH LOCATION

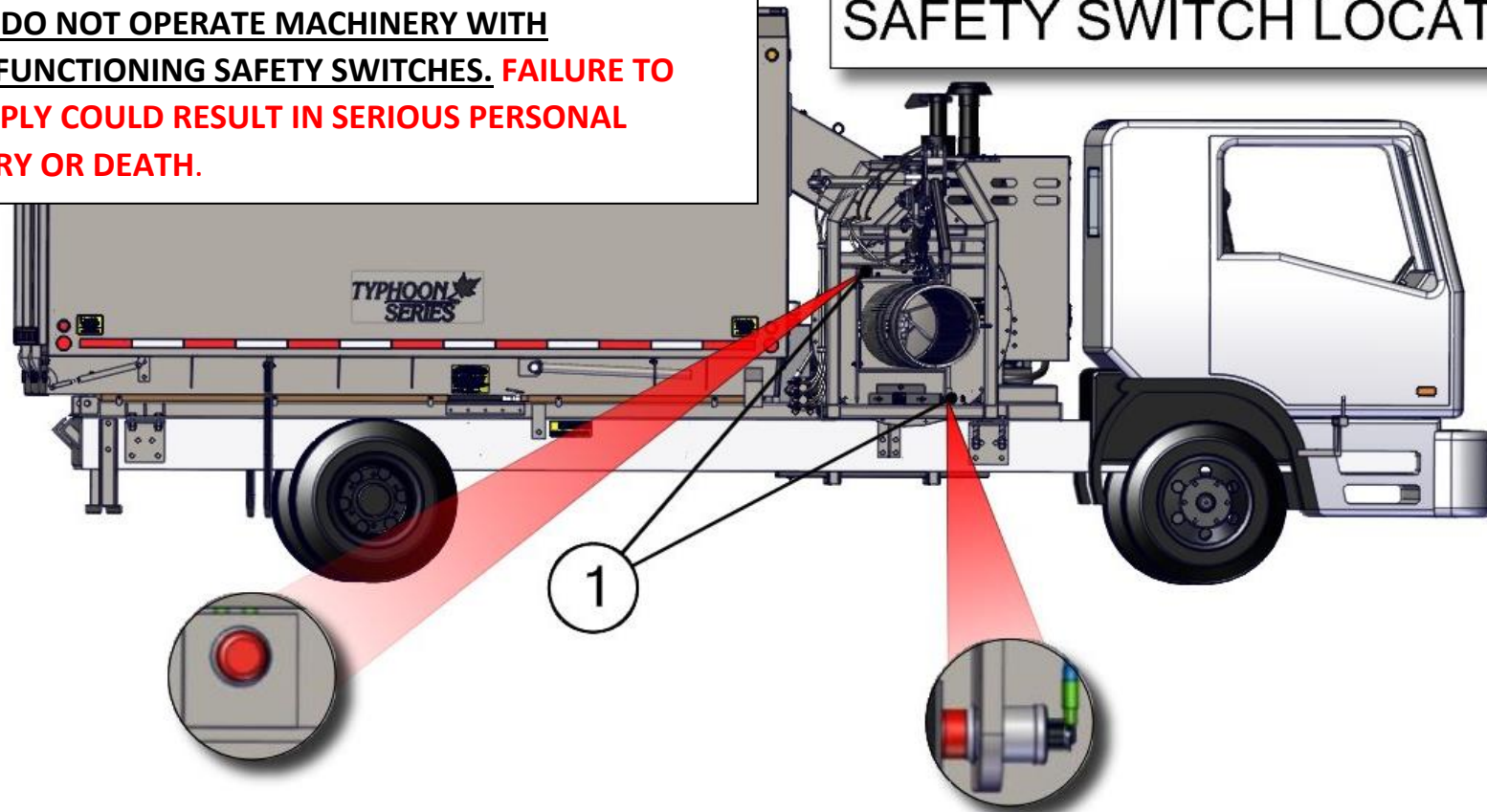

BOM ID	JDENumber (config)	Description (config)	Qty
1	32314	Switch, Safety	2



*****DO NOT GO UNDER DUMP BOX UNLESS BOX IS EMPTY AND PROPS ARE SECURED IN THE LOCKED OPEN POSITION*****



A WARNING SYMBOL INDICATES A HAZARDOUS SITUATION WHICH, IF NOT AVOIDED, COULD RESULT IN SERIOUS INJURY OR DEATH.

IF THE BODY LOWERS AND THE PROPS ARE NOT LOCKED IN PLACE ANY PERSON UNDER IT COULD BE CRUSHED TO DEATH OR HAVE SERIOUS INJURIES AS A RESULT.

TARCO® TYPHOON
SAFETY PROP LOCATIONS

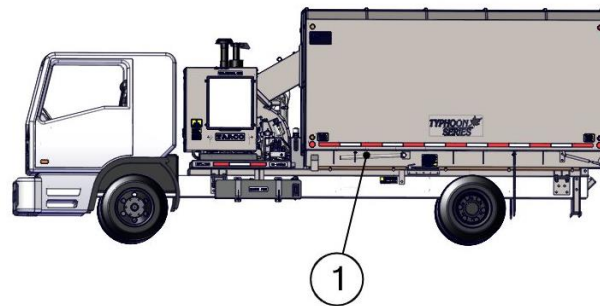

BOM ID	JDENumber (config)	Description (config)	Qty
1	28990	Safety Prop Assembly	2

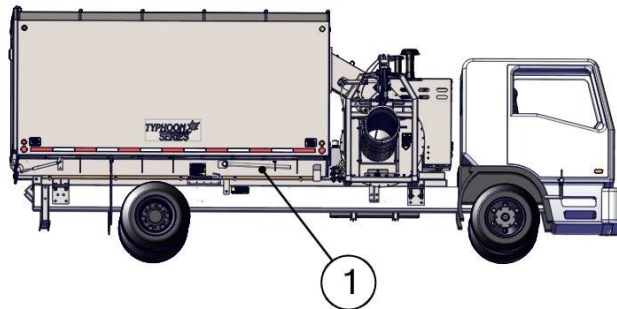

PASSENGER SIDE LIGHTS

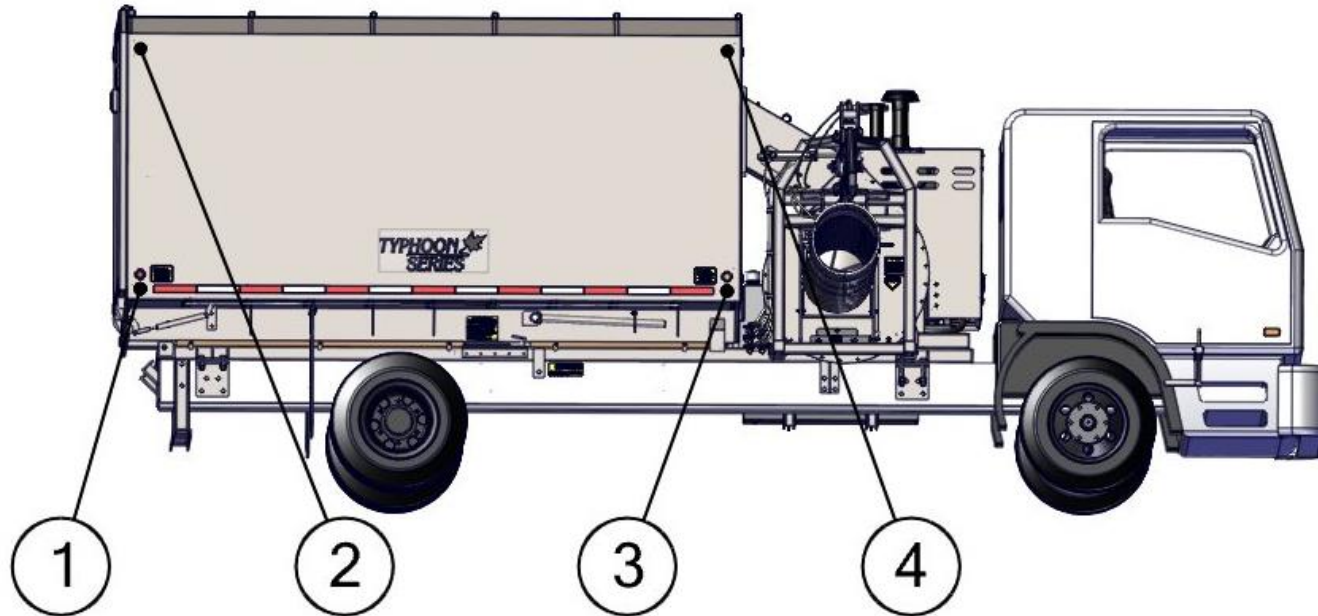

BOM ID	JDENumber (config)	Description (config)	Qty
1	28043	Reflector-Red	1
2	32824	Light, 2" LED Red	2
3	28044	Reflector-Amber	1
4	28035	Light Clearance - 2" Amber LED	2

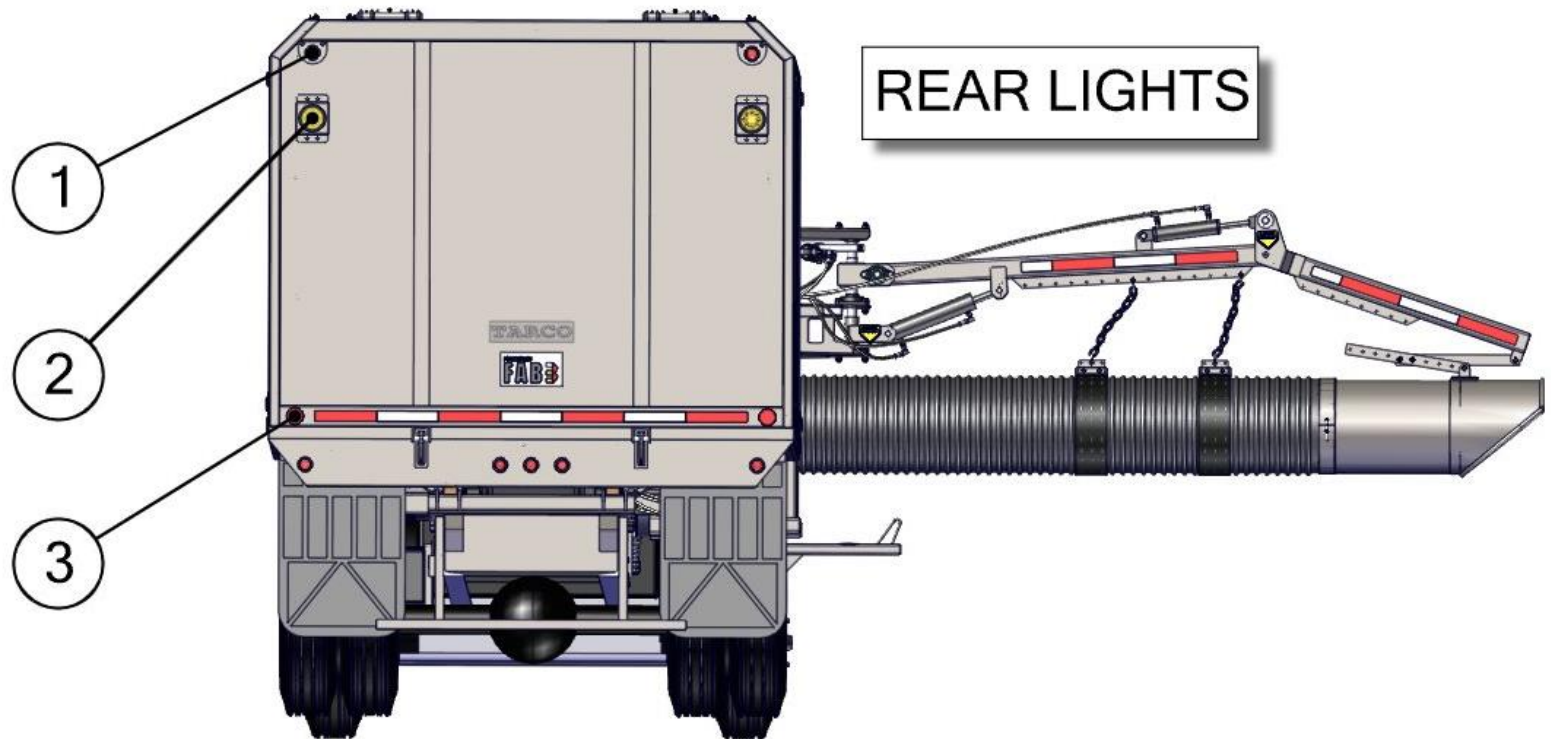

BOM ID	JDENumber (config)	Description (config)	Qty
1	32824	Light, 2" LED Red	7
2	33462	Light, 4" Amber LED	2
3	28043	Reflector-Red	2

DRIVER SIDE LIGHTS

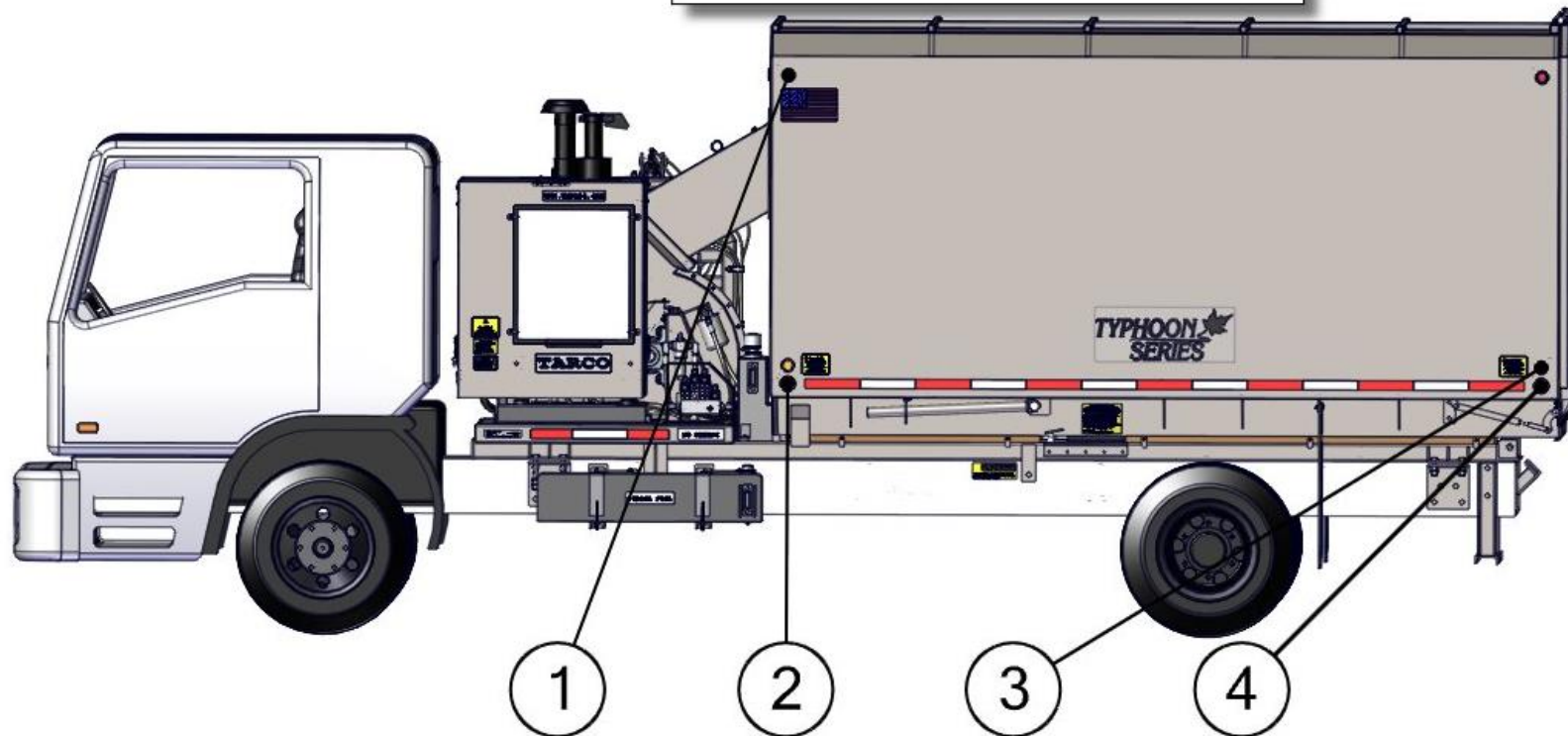

BOM ID	JDENumber (config)	Description (config)	Qty
1	28035	Light Clearance - 2" Amber LED	2
2	28044	Reflector-Amber	1
3	32824	Light, 2" LED Red	2
4	28043	Reflector-Red	1



CAB CONTROL LOCATION

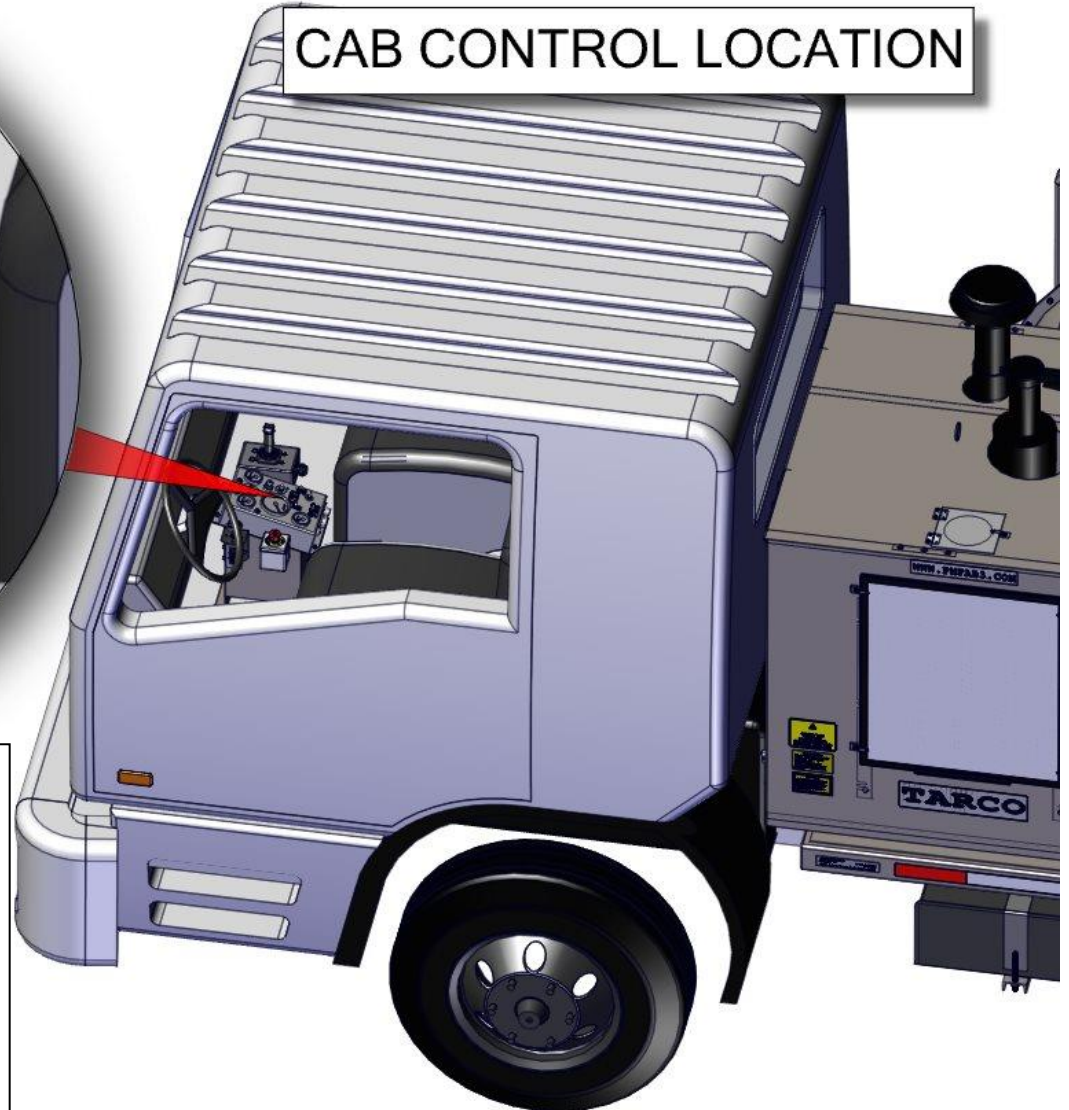

⚠ WARNING EMERGENCY STOPS NEED TO BE CHECKED FOR CORRECT OPERATION BEFORE EACH USE. DO NOT OPERATE MACHINERY WITH MALFUNCTIONING EMERGENCY STOPS. FAILURE TO COMPLY COULD RESULT IN SERIOUS PERSONAL INJURY OR DEATH.

CAB CONTROLS

MURPHY CONTROL

ENGINE
CONTROLS



TAILGATE CONTROL

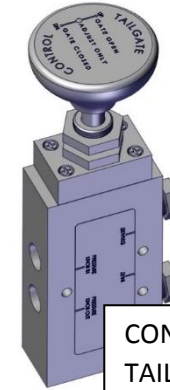

CONTROLS
TAILGATE

6 Axis Joy Stick & Box Ass'ly

CONTROLS
BOOM



EMERGENCY STOP

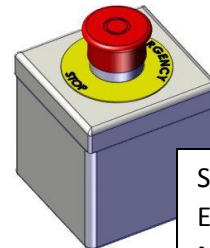

SHUTS DOWN THE
ENGINE AND SUCTION
MECHANISM

⚠ WARNING EMERGENCY STOPS NEED TO BE CHECKED FOR CORRECT OPERATION BEFORE EACH USE. DO NOT OPERATE MACHINERY WITH MALFUNCTIONING EMERGENCY STOPS. FAILURE TO COMPLY COULD RESULT IN SERIOUS PERSONAL INJURY OR DEATH.

PASSENGER SIDE DECALS

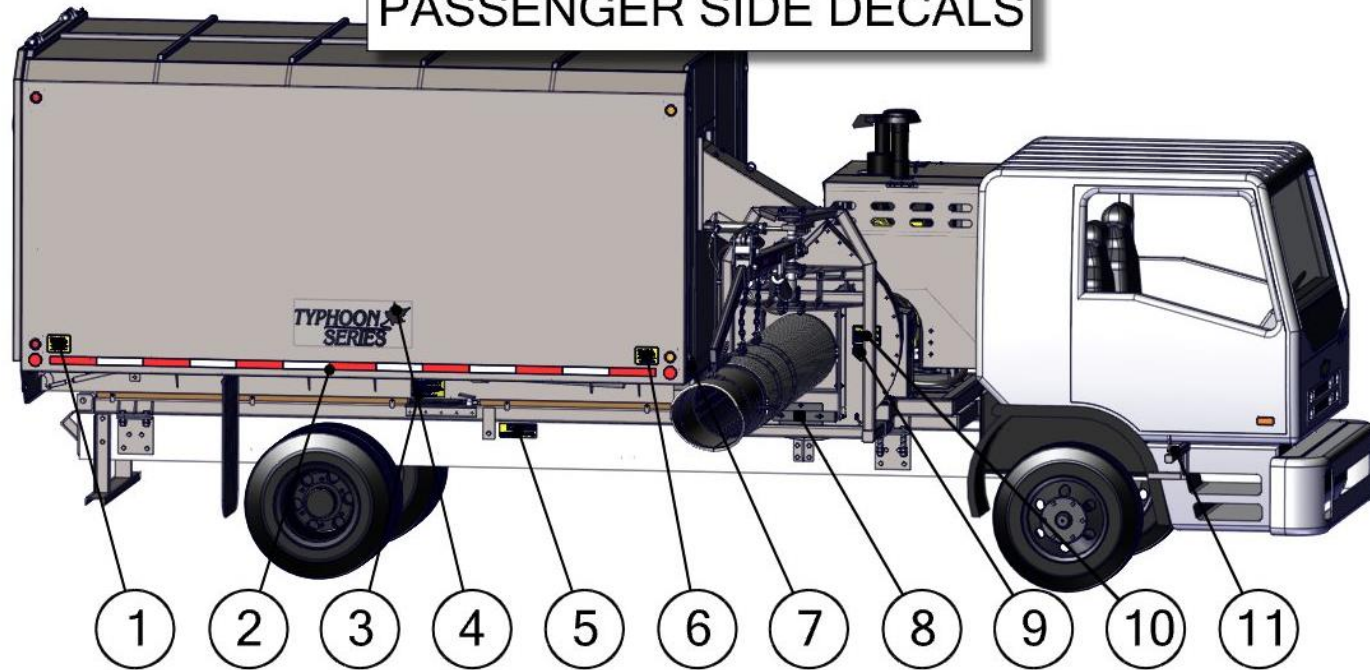

BOM ID	JDENumber (config)	Description (config)	Qty
1	27714	Decal - Do Not Climb or Work	1
2	28318	Tape-Conspicuity 2" Wide	1
3	27501	Decal - Caution Body Prop	1
4	33534	Decal "Typhoon Series"Black	1
5	27499	Decal - Caution Safety Prop	1
6	27714	Decal - Do Not Climb or Work	1

BOM ID	JDENumber (config)	Description (config)	Qty
7	27714	Decal - Do Not Climb or Work	1
8	27507	Decal - Safety First	1
9	27561	Decal - Danger - Keep Hand and	1
10	27548	Decal-Warning Danger-Do Not	1
11	27561	Decal - Danger - Keep Hand and	1

DO NOT OPERATE EQUIPMENT IF ANY DECALS THAT CAME WITH THE PRODUCT OR WERE LATER SENT TO YOU BY FORT MILLER FAB3 ARE MISSING OR DAMAGED. THE ABOVE DIAGRAM ILLUSTRATES THE LOCATION AND NATURE OF THE WARNINGS THAT MUST BE ON THE PRODUCT: TO OBTAIN REPLACEMENT DECALS THAT ARE MISSING OR DAMAGED CONTACT FORT MILLER FAB3 AT (518)584-4400 OR WWW.FMFAB3.COM

REAR DECALS

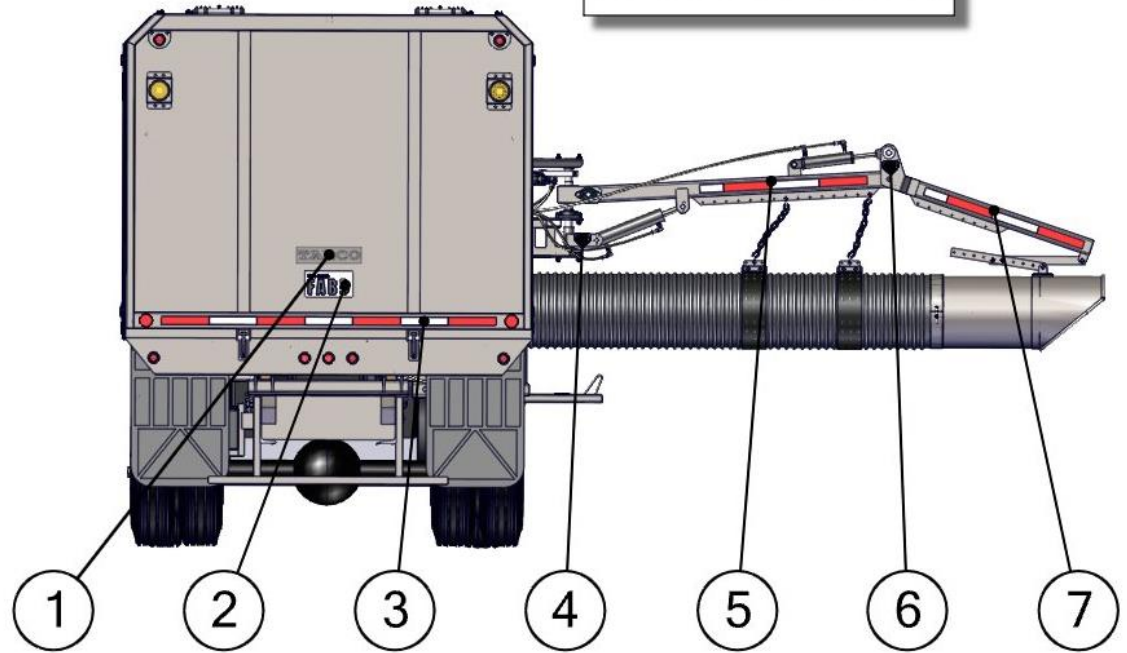

BOM ID	JDENumber (config)	Description (config)	Qty
1	27585	Decal - Tarco	1
2	29759	Decal - FMFAB3	1
3	28318	Tape-Conspicuity 2" Wide	1
4	27561	Decal - Danger - Keep Hand and	1
5	28318	TAPE - CONSPICUITY 2" WIDE X 42"	1
6	27561	Decal - Danger - Keep Hand and	1
7	28318	TAPE - CONSPICUITY 2" WIDE X 42"	1

DO NOT OPERATE EQUIPMENT IF ANY DECALS THAT CAME WITH THE PRODUCT OR WERE LATER SENT TO YOU BY FORT MILLER FAB3 ARE MISSING OR DAMAGED. THE ABOVE DIAGRAM ILLUSTRATES THE LOCATION AND NATURE OF THE WARNINGS THAT MUST BE ON THE PRODUCT: TO OBTAIN REPLACEMENT DECALS THAT ARE MISSING OR DAMAGED CONTACT FORT MILLER FAB3 AT (518)584-4400 OR WWW.FMFAB3.COM

DRIVER SIDE DECALS

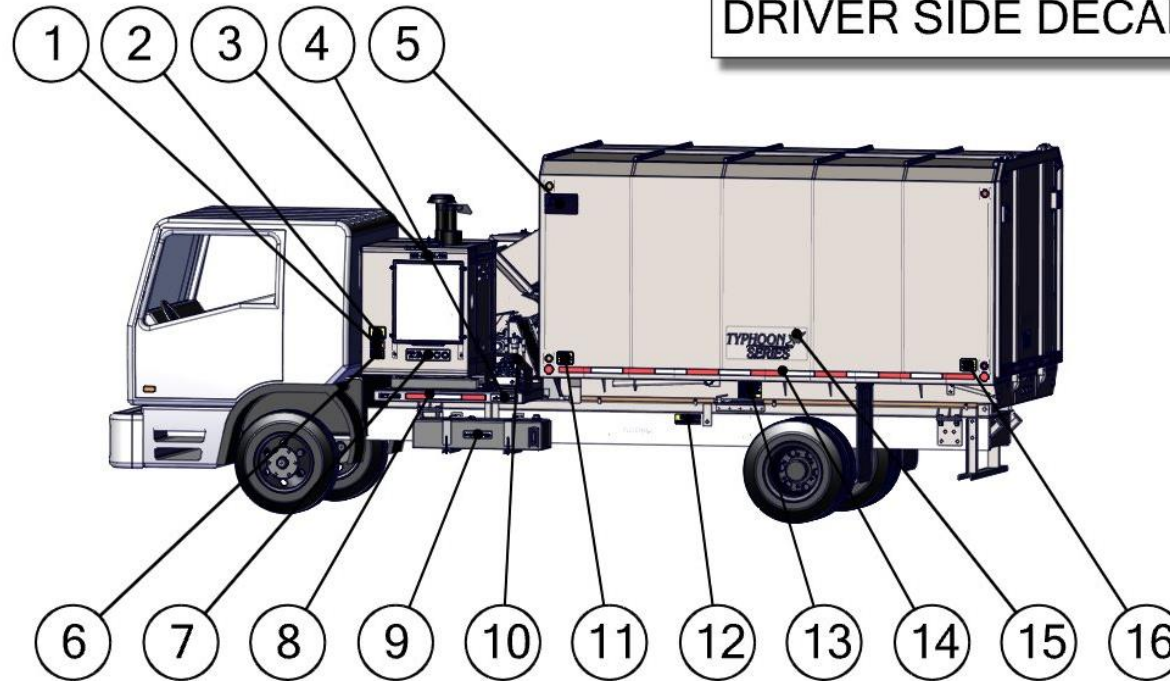

BOM ID	JDNumber (config)	Description (config)	Qty
1	27503	Decal - Mylar-Do Not Engage or	1
2	27713	Decal - Do Not Operate This	1
3	29761	Decal - www.FMFAB3.COM	1
4	27488	Decal - No Riders	1
5	27571	Decal - American Flag	1
6	27542	Decal - Danger-Before	1
7	27585	Decal - Tarco	1
8	28318	TAPE - CONSPICUITY 2" WIDE X 30"	1
9	27578	Decal - Diesel Fuel	1

BOM ID	JDNumber (config)	Description (config)	Qty
10	27507	Decal - Safety First	1
11	27714	Decal - Do Not Climb or Work	1
12	27499	Decal - Caution Safety Prop	1
13	27501	Decal - Caution Body Prop	1
14	28318	Tape-Conspicuity 2" Wide	1
15	33534	Decal "Typhoon Series"Black	1
16	27714	Decal - Do Not Climb or Work	1

DO NOT OPERATE EQUIPMENT IF ANY DECALS THAT CAME WITH THE PRODUCT OR WERE LATER SENT TO YOU BY FORT MILLER FAB3 ARE MISSING OR DAMAGED. THE ABOVE DIAGRAM ILLUSTRATES THE LOCATION AND NATURE OF THE WARNINGS THAT MUST BE ON THE PRODUCT: TO OBTAIN REPLACEMENT DECALS THAT ARE MISSING OR DAMAGED CONTACT FORT MILLER FAB3 AT (518)584-4400 OR WWW.FMFAB3.COM

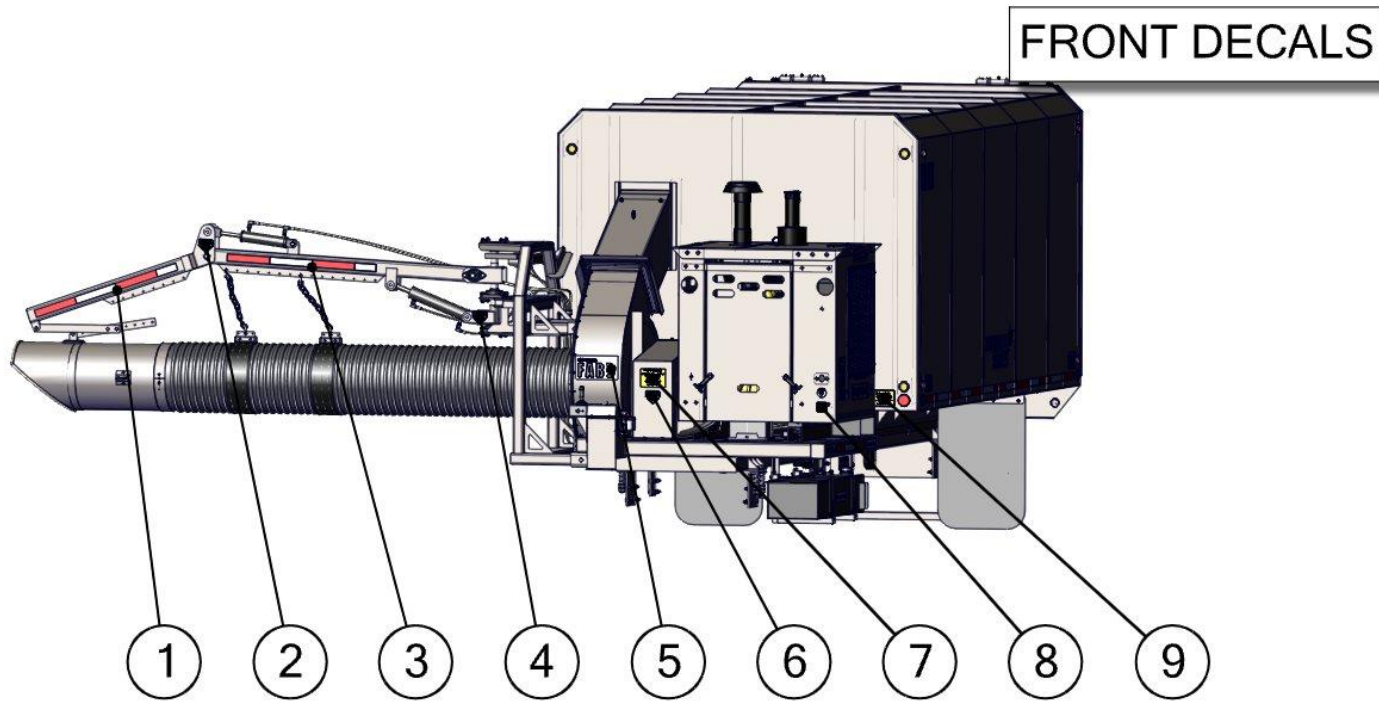

BOM ID	JDENumber (config)	Description (config)	Qty
1	28318	TAPE - CONSPICUITY 2" WIDE X 42"	1
2	27561	Decal - Danger - Keep Hand and	1
3	28318	TAPE - CONSPICUITY 2" WIDE X 42"	1
4	27561	Decal - Danger - Keep Hand and	1
5	29759	Decal - FMFAB3	1

BOM ID	JDENumber (config)	Description (config)	Qty
6	27561	Decal - Danger - Keep Hand and	1
7	27490	Decal - Bearing Lubrication	1
8	27507	Decal - Safety First	1
9	27714	Decal - Do Not Climb or Work	1

DO NOT OPERATE EQUIPMENT IF ANY DECALS THAT CAME WITH THE PRODUCT OR WERE LATER SENT TO YOU BY FORT MILLER FAB3 ARE MISSING OR DAMAGED. THE ABOVE DIAGRAM ILLUSTRATES THE LOCATION AND NATURE OF THE WARNINGS THAT MUST BE ON THE PRODUCT: TO OBTAIN REPLACEMENT DECALS THAT ARE MISSING OR DAMAGED CONTACT FORT MILLER FAB3 AT (518)584-4400 OR WWW.FMFAB3.COM

TOP DECALS

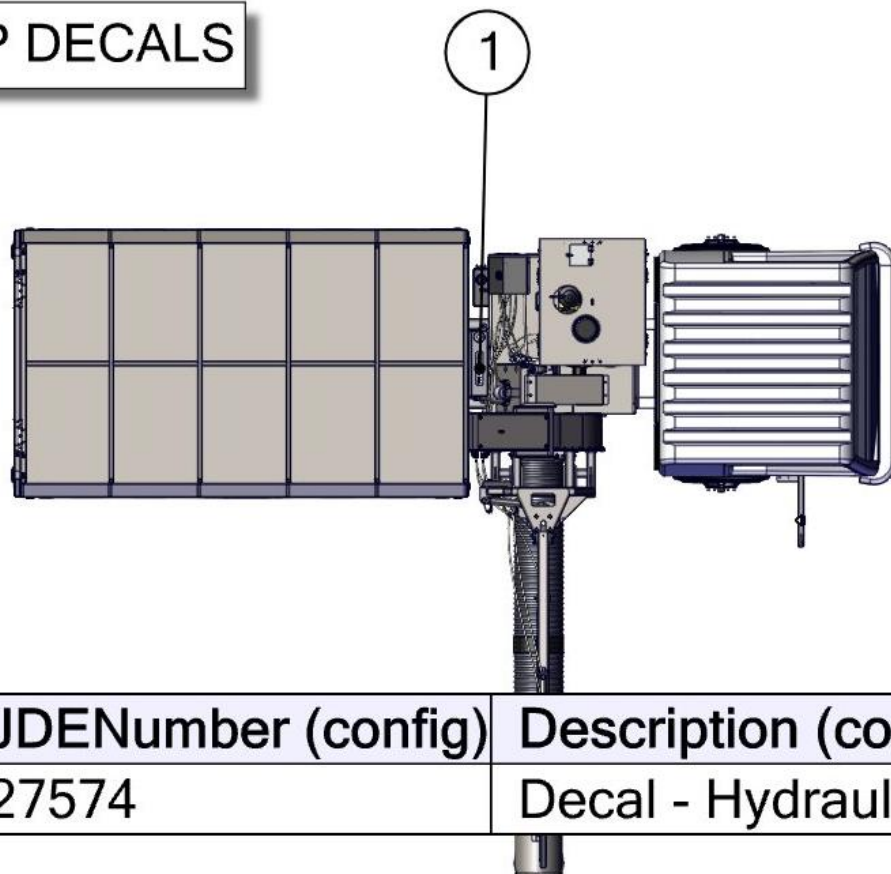

BOM ID	JDENumber (config)	Description (config)	Qty
1	27574	Decal - Hydraulic Oil	1

DO NOT OPERATE EQUIPMENT IF ANY DECALS THAT CAME WITH THE PRODUCT OR WERE LATER SENT TO YOU BY FORT MILLER FAB3 ARE MISSING OR DAMAGED. THE ABOVE DIAGRAM ILLUSTRATES THE LOCATION AND NATURE OF THE WARNINGS THAT MUST BE ON THE PRODUCT: TO OBTAIN REPLACEMENT DECALS THAT ARE MISSING OR DAMAGED CONTACT FORT MILLER FAB3 AT (518)584-4400 OR WWW.FMFAB3.COM

DECAL IDENTIFICATION



COMPANY LOGO

LOCATION DETAIL SEE PAGE 23 ITEM 2
LOCATION DETAIL SEE PAGE 25 ITEM 5

JDE# 29759 (7500-1) QTY=2



JDE# 27499 (7500-31) QTY=2

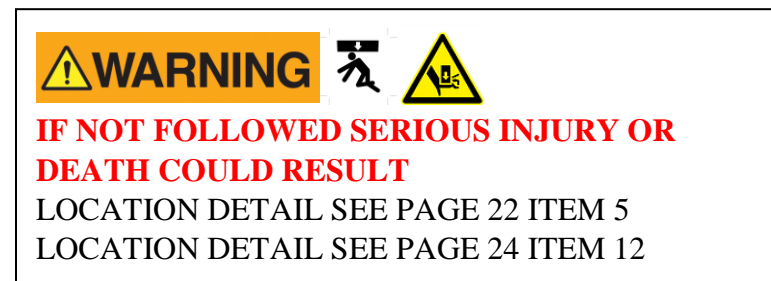

BODY PROP OPERATION
BE SURE BODY IS UNLOADED BEFORE USING PROPS

WARNING WHEN TWO PROPS ARE INSTALLED ON THE VEHICLE BOTH MUST BE USED.

TO USE:

1. RAISE BODY TO A HEIGHT WHERE PROPS CAN BE SWUNG INTO POSITION.
2. BE SURE HOIST CONTROL VALVE IS IN NEUTRAL POSITION.
3. REMOVE TRANSIT POSITION BODY PROP RETAINERS AND SWING BODY PROPS INTO SUPPORT POSITION.
4. LOWER BODY ONTO THE BODY PROPS AND VISUALLY INSPECT TO SEE THAT BOTH ARE SECURE BEFORE PREFORMING ANY WORK. IF HOIST IS DOUBLE ACTING, **DO NOT POWER BODY DOWN ON PROPS (GRAVITY LOWER ONLY)**. BE SURE HOIST CONTROL VALVE IS IN THE NEUTRAL POSITION WITH THE LEVER LOCKOUT ENGAGED IN THE LOCK POSITION.

TO STORE:

5. RAISE BODY SLIGHTLY.
6. RETURN PROPS TO TRANSIT POSITION AND INSTALL RETAINERS.

IF NOT AVOIDED, COULD RESULT IN DEATH OR SERIOUS INJURY.
FM FAB3, GREENWICH, NY

JDE# 27501 (7500-32) QTY=2

NOTICE

DO NOT ENGAGE OR DISENGAGE CLUTCH IF ENGINE EXCEEDS 800 - 1000 R.P.M
FREQUENT INITIAL CLUTCH ADJUSTMENTS ARE NECESSARY.
(SEE CLUTCH PTO INSTRUCTION BOOK FURNISHED WITH ENGINE.)

JDE# 27503 (7500-34) QTY=1

WARNING   

IF NOT FOLLOWED SERIOUS INJURY, DEATH OR EQUIPMENT DAMAGE COULD RESULT

LOCATION DETAIL SEE PAGE 22 ITEM 3
LOCATION DETAIL SEE PAGE 24 ITEM 13

NOTICE

MACHINE DAMAGE WILL RESULT IF NOT FOLLOWED

LOCATION DETAIL SEE PAGE 24 ITEM 1



JDE# 27507 (7500-36) QTY=3



JDE# 27542 (7500-43) QTY=1





JDE# 27548 (7500-46) QTY=1



JDE# 27561 (7500-87) QTY=7



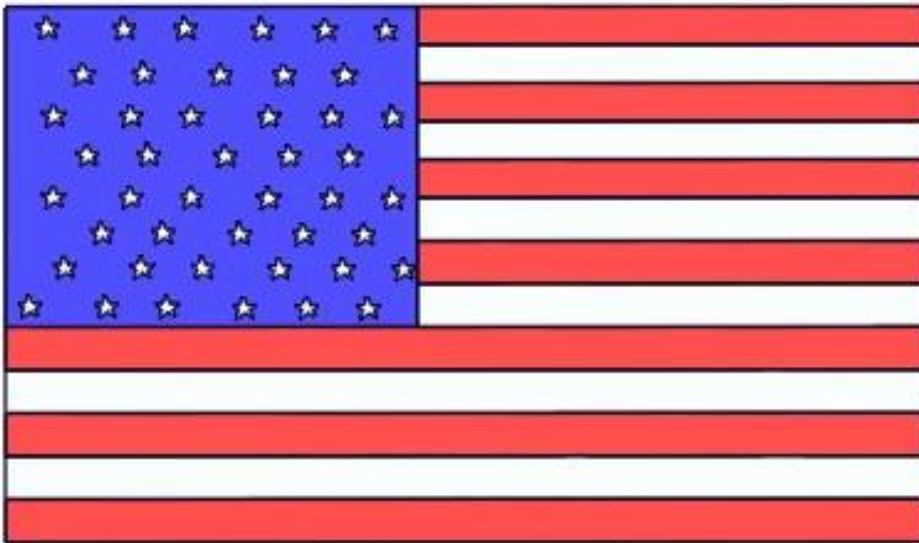

JDE# 27571 (7500-90) QTY=1

HYDRAULIC OIL

JDE# 27574 (7500-91) QTY=1

MADE IN THE USA

LOCATION DETAIL SEE PAGE 24 ITEM 5

NOTICE

**MACHINE DAMAGE WILL RESULT IF
NOT FOLLOWED**

LOCATION DETAIL SEE PAGE 26 ITEM 1

DIESEL FUEL

JDE# 27578 (7500-92) QTY=1

NOTICE

**MACHINE DAMAGE WILL RESULT IF
NOT FOLLOWED**

LOCATION DETAIL SEE PAGE 24 ITEM 9

TARCO

JDE# 27585 (7500-94) QTY=2

COMPANY BRAND

LOCATION DETAIL SEE PAGE 23 ITEM 1

LOCATION DETAIL SEE PAGE 24 ITEM 7



JDE# 27713 (7500-98) QTY=1



JDE# 27714 (7500-99) QTY=6

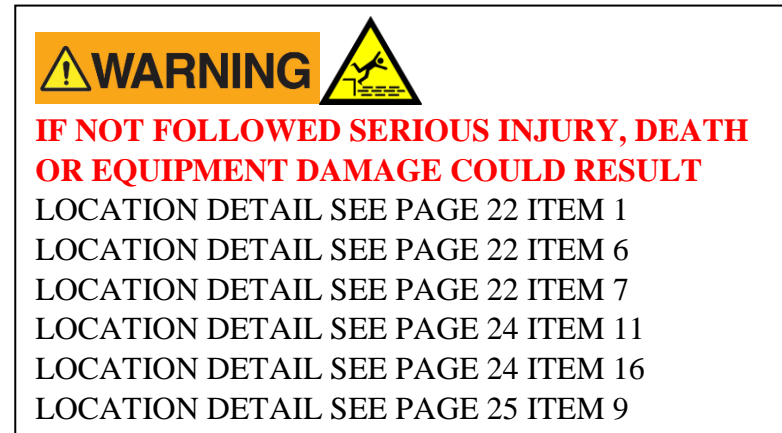

www.fmfab3.com

CONTACT INFORMATION

LOCATION DETAIL SEE PAGE 24 ITEM 3

JDE# 29761 (7500-101) QTY=1



**IF NOT FOLLOWED SERIOUS INJURY, OR
DEATH COULD RESULT**

LOCATION DETAIL SEE PAGE 24 ITEM 4

JDE# 27488 (7500-102) QTY=1



USE CAUTION POTENTIAL HAZARD

LOCATION DETAIL SEE PAGE 22 ITEM 2

LOCATION DETAIL SEE PAGE 23 ITEM 3

LOCATION DETAIL SEE PAGE 23 ITEM 5

LOCATION DETAIL SEE PAGE 23 ITEM 7

LOCATION DETAIL SEE PAGE 24 ITEM 8

LOCATION DETAIL SEE PAGE 24 ITEM 14

LOCATION DETAIL SEE PAGE 25 ITEM 1

LOCATION DETAIL SEE PAGE 25 ITEM 3



JDE# 28318 (60033-56) QTY=8

NOTICE

BEARING LUBRICATION INSTRUCTIONS

DO NOT OVER LUBRICATE BEARINGS
OUTDOOR SERVICE
(PER MFG. SPECIFICATIONS)
2 - 3 TIMES PER YEAR
RELUBRICATE UNTIL A THIN BEAD OF
FRESH GREASE IS VISIBLE AT THE
SEAL LIP
HAND GREASE GUN ONLY!

NOTICE

MACHINE DAMAGE WILL RESULT IF NOT FOLLOWED
LOCATION DETAIL SEE PAGE 25 ITEM 7

JDE# 27490 (7500-103) QTY=1



JDE# 33534 (33534) QTY=2

MACHINE NAME

LOCATION DETAIL SEE PAGE 22 ITEM 4
LOCATION DETAIL SEE PAGE 24 ITEM 15