

****KEEP THIS MANUAL****

TARCO® T-4000
SAFETY MANUAL

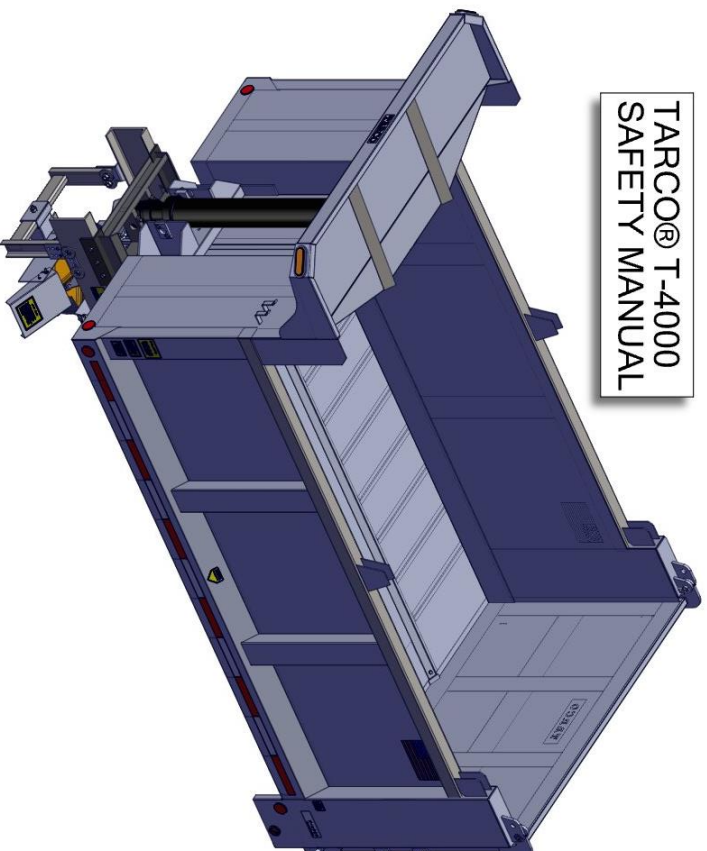

FORT MILLER FAB3 CORP.
678 WILBUR AVE.
GREENWICH, NY 12834
www.fmfab3.com
TEL. 518-584-4400
FAX. 518-584-6630

**WARNING**

Read and understand operator's manual before using this equipment.

Failure to follow operating instructions could result in death or serious injury.

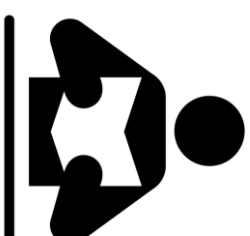

****IMPORTANT SAFETY INFORMATION****



Thank you and congratulations on your recent purchase.
Please take time reading and understanding the manual before operating the equipment.
Fill in the following information, so that it is at hand when needed.

MODEL _____
SERIAL NO. _____
DATE OF PURCHASE _____



*****The operator must carefully read and follow any warnings, safety sign and instructions provided with or located on the equipment. *****

*****Please keep a copy of the manual in the cab so that it may be consulted by the operator. *****





*****Do not allow untrained operators to use this equipment as serious injury, death or equipment damage could result. *****

FOR WARNING/NOTICE DECALS THAT ARE MISSING OR NOT LEGIBLE, OR FOR MANUAL REPLACEMENT COPIES, OR IF YOU HAVE QUESTIONS OR CONCERNS CONTACT FORT MILLER FAB3
(518)-584-4400 or www.fmfab3.com

****IMPORTANT SAFETY INFORMATION****

SIGNAL WORDS & DEFINITIONS

SYMBOLS USED IN THE MANUAL AND ON THE MACHINERY

	SAFETY ALERT SYMBOL USED TO ALERT OF POTENTIAL PERSONAL INJURY HAZARDS. OBEY ALL SAFETY MESSAGES THAT FOLLOW THIS SYMBOL TO AVOID POSSIBLE INJURY OR DEATH.
	DANGER INDICATES A HAZARDOUS SITUATION WHICH, IF NOT AVOIDED, WILL RESULT IN DEATH OR SERIOUS INJURY.
	WARNING INDICATES A HAZARDOUS SITUATION WHICH, IF NOT AVOIDED, COULD RESULT IN DEATH OR SERIOUS INJURY.
	CAUTION USED WITH THE SAFETY ALERT SYMBOL, INDICATES A HAZARDOUS SITUATION WHICH, IF NOT AVOIDED, COULD RESULT IN MINOR OR MODERATE INJURY.
	NOTICE IS USED TO ADDRESS PRACTICES NOT RELATED TO PERSONAL INJURY.

*****FOR WARNING/NOTICE DECALS THAT ARE MISSING OR NOT LEGIBLE, OR FOR MANUAL REPLACEMENT COPIES, OR IF YOU HAVE QUESTIONS OR CONCERNS CONTACT FORT MILLER FAB3*****

(518)-584-4400 or www.fmfab3.com

****IMPORTANT SAFETY INFORMATION****



A WARNING SYMBOL INDICATES A HAZARDOUS SITUATION WHICH, IF NOT AVOIDED, COULD RESULT IN SERIOUS INJURY OR DEATH.

- **⚠ WARNING** DO NOT OPERATE MACHINERY WITHOUT READING AND UNDERSTANDING THIS MANUAL. **FAILURE TO FOLLOW THIS INFORMATION CAN LEAD TO MACHINE DAMAGE, SERIOUS INJURY, OR EVEN DEATH.**
- **⚠ WARNING** USE ALL MACHINERY FOR ITS INTENDED USE. **FAILURE TO FOLLOW THIS INFORMATION CAN LEAD TO MACHINE DAMAGE, SERIOUS INJURY, OR EVEN DEATH.**
- **⚠ WARNING** DO NOT MODIFY EQUIPMENT. **FAILURE TO FOLLOW THIS INFORMATION CAN LEAD TO MACHINE DAMAGE, SERIOUS INJURY, OR EVEN DEATH.**
- **⚠ WARNING** ANY MISS USE OR MODIFICATION TO THE EQUIPMENT **CAN LEAD TO MACHINE DAMAGE, SERIOUS INJURY, OR EVEN DEATH.**
- **⚠ WARNING** DO NOT RIDE ON MACHINERY. **FAILURE TO FOLLOW THIS INFORMATION CAN LEAD TO MACHINE DAMAGE, SERIOUS INJURY, OR EVEN DEATH.**

FOR WARNING/NOTICE DECALS THAT ARE MISSING OR NOT LEGIBLE, OR FOR MANUAL REPLACEMENT COPIES, OR IF YOU HAVE QUESTIONS OR CONCERNS CONTACT FORT MILLER FAB3
(518)-584-4400 or www.fmfab3.com

****IMPORTANT SAFETY INFORMATION****

IMPORTANT SAFETY INFORMATION

TO THE OPERATOR

Prior to using the TARCO® T-4000, you must be properly trained in the full operation of the machine. This would include but not be limited to a complete review of the operating and safety manual and a complete understanding of all safety procedures including the safety decals and information on the machine. If there is something you do not understand, ask your supervisor to explain it to you. If you require additional manuals or decals, please contact your dealer or the manufacturer.

Make sure all the manufacturers' protective guards, shields, and screens are in good repair, in place, and securely fastened. Damaged, missing, or weakened safety components can create a hazardous situation for the operator and bystanders. NEVER remove or modify any safety components on this equipment.

Wear all the protective clothing and personal safety devices issued to you or called for by the job conditions. This may include but is not limited to a hard hat, safety shoes, safety glasses or goggles, heavy gloves, hearing protection, reflective clothing or wet weather gear. Remember, you are responsible for your safety and that of your co-workers. Good safety practices protect you and the people around you.

NEVER ride on any part of the equipment when operating the machine or at any time. Never modify the machine for riders in any way other than inside the cab. Prior to operating this machine, be certain that all operators can ride safely in the truck or vehicle being used. If your machine has been altered to accommodate riders, remove these alterations immediately as this can result in serious injury or death. A "NO RIDERS" decal should be in place. Please request these from your dealer or use the web to contact and request them from Fort Miller FAB3 Corp. (518)-584-4400 or www.fmfab3.com.

****IMPORTANT SAFETY INFORMATION****

A WORD ABOUT SAFETY:

The Tarco® T-4000 Combination Dump Body/Spreader described in this manual can be operated year round during conditions with bad weather such as snow & ice conditions. Due to these adverse operating conditions it is important that you the operator use good safety practices at all times to protect yourself and co-workers and others when using this machine.

It is not practical or possible to warn you about all the hazards associated with the operation and maintenance of this machine. You must use your own good judgement supplemented with the information found on the safety decals, instructions in this manual, your employer's safety programs, safety codes, local, state/provincial, and federal laws, rules and regulations.

When performing maintenance on this machine, trouble shooting the operations of the machine, loading or unloading the machine with material or operating the machine observe & obey all safety decals on the machine and warnings listed in the manual. Failure to do this could result in serious injury or death to you or others.

Remember at all times that as the operator you are responsible for the safe operation of this equipment and are responsible for the safety of others. Good safety practices not only protect you but also protect the people around you.

FOR WARNING/NOTICE DECALS THAT ARE MISSING OR NOT LEGIBLE, OR FOR MANUAL REPLACEMENT COPIES, OR IF YOU HAVE QUESTIONS OR CONCERNS CONTACT FORT MILLER FAB3
(518)-584-4400 or www.fmfab3.com

****IMPORTANT SAFETY INFORMATION****



A WARNING SYMBOL INDICATES A HAZARDOUS SITUATION WHICH, IF NOT AVOIDED, COULD RESULT IN SERIOUS INJURY OR DEATH



- ⚠ WARNING** DO NOT operate unit without wearing proper safety equipment as described in this manual.
- ⚠ WARNING** DO NOT operate, maintain or repair this unit without fully reading and understanding ALL aspects of this manual.
- ⚠ WARNING** DO NOT make any adjustment or repairs before proper LOCK OUT/TAG OUT is performed.
- ⚠ WARNING** DO NOT operate the unit while under the influence of alcohol, drugs, or any medication that could impair operating abilities.
- ⚠ WARNING** DO NOT operate the unit with ANY guards or safety devices broken, missing, or inoperable.
- ⚠ WARNING** DO NOT operate the unit without fully inspecting the unit for any damage or leakage.
- ⚠ WARNING** DO NOT use equipment that is not safe.
- ⚠ WARNING** DO NOT operate the unit if all operating controls and safety devices are not in good working order.
- ⚠ WARNING** DO NOT operate unit in a state of disrepair.
- ⚠ WARNING** DO NOT ride, sit or stand on the unit while in use.
- ⚠ WARNING** DO NOT place hands or feet near moving or rotating parts.
- ⚠ WARNING** DO NOT jump from the vehicle.

*****FOR WARNING/NOTICE DECALS THAT ARE MISSING OR NOT LEGIBLE, OR FOR MANUAL REPLACEMENT COPIES, OR IF YOU HAVE QUESTIONS OR CONCERNS CONTACT FORT MILLER FAB3*****

(518)-584-4400 or www.fmfab3.com

****IMPORTANT SAFETY INFORMATION****

- ⚠ WARNING** DO NOT allow personnel to ride anywhere, except in the cab, when the unit or vehicle is in operation.
- ⚠ WARNING** DO NOT modify the unit for any reason to allow for riders.
- ⚠ WARNING** DO NOT exceed weight limitations.
- ⚠ WARNING** DO NOT smoke or weld near the unit.
- ⚠ WARNING** DO NOT leave machine running unattended.
- ⚠ WARNING** DO NOT park unit on a steep grade or slope.
- ⚠ WARNING** DO NOT go under a raised dump body unless it is empty and all props are locked in place.
- ⚠ WARNING** DO NOT lock props in place until dump body is empty.
- ⚠ WARNING** DO NOT raise dump body near any power lines or low tree branches.
- ⚠ WARNING** DO NOT raise dump body on an uneven or soft surface.
- ⚠ WARNING** DO NOT lower dump body without a complete visual check of the body area.
- ⚠ WARNING** DO NOT unload or load on uneven surfaces.
- ⚠ WARNING** DO NOT lift both the dump body and floor at the same time.
- ⚠ WARNING** DO NOT operate on recently excavated ground or in filling ground if the soil was not properly compacted.
- ⚠ WARNING** DO NOT stand in the cylinder operation area when in action.
- ⚠ WARNING** DO NOT stand in the area of outflow.

FOR WARNING/NOTICE DECALS THAT ARE MISSING OR NOT LEGIBLE, OR FOR MANUAL REPLACEMENT COPIES, OR IF YOU HAVE QUESTIONS OR CONCERNS CONTACT FORT MILLER FAB3

(518)-584-4400 or www.fmfab3.com

****IMPORTANT SAFETY INFORMATION****

- ⚠ WARNING** DO NOT stand near the spreader mechanism while in operation.
- ⚠ WARNING** DO NOT stand inside the dump body when the conveyor is in operation.
- ⚠ WARNING** DO NOT operate the truck with a defective back up alarm. Fix immediately if defective.
- ⚠ WARNING** DO NOT operate the truck with a defective body up indicator light. Fix immediately if defective.
- ⚠ WARNING** DO NOT work under a raised dump body unless it is empty and all props are locked in place.



A WARNING SYMBOL INDICATES A HAZARDOUS SITUATION WHICH, IF NOT AVOIDED, COULD RESULT IN SERIOUS INJURY OR DEATH

- ⚠ WARNING** DO wear proper safety equipment as described in this manual.
- ⚠ WARNING** DO completely read and understand the owner's manual before operating, maintaining, or repairing this equipment.
- ⚠ WARNING** DO perform proper LOCK OUT/TAG OUT before any adjustment or repairs are made.
- ⚠ WARNING** DO remove the negative battery cable before doing any maintenance on the unit.
- ⚠ WARNING** DO follow and obey ALL safety regulations.
- ⚠ WARNING** DO replace any worn or missing safety decals immediately contact: (518)584-4400 or at www.fmfab3.com
- ⚠ WARNING** DO completely inspect the unit before leaving the service garage.

*****FOR WARNING/NOTICE DECALS THAT ARE MISSING OR NOT LEGIBLE, OR FOR MANUAL REPLACEMENT COPIES, OR IF YOU HAVE QUESTIONS OR CONCERNS CONTACT FORT MILLER FAB3***
(518)-584-4400 or www.fmfab3.com**

****IMPORTANT SAFETY INFORMATION****

- ⚠ WARNING** DO watch for pedestrians, animals, and other foreign objects when operating this unit.
- ⚠ WARNING** DO use a spotter when backing.
- ⚠ WARNING** DO make sure the truck is in a stable position on level ground before starting to lift the dump body or Floor.
- ⚠ WARNING** DO observe for any overhead obstructions prior to dumping.
- ⚠ WARNING** DO make sure the rear tailgate is free before starting to lift the dump body.
- ⚠ WARNING** DO at all time be in control of the operation when out flowing.
- ⚠ WARNING** DO make sure the dump body is empty before locking the safety props.
- ⚠ WARNING** DO insert the body props before going under the raised body for any reason.
- ⚠ WARNING** DO make sure that when the dump body is not in operation that it is laying on the truck's frame before driving.
- ⚠ WARNING** DO observe for any overhead obstructions prior to dumping.
- ⚠ WARNING** DO make sure the opening control of rear gate is in the closed position when truck is moving.

FOR WARNING/NOTICE DECALS THAT ARE MISSING OR NOT LEGIBLE, OR FOR MANUAL REPLACEMENT COPIES, OR IF YOU HAVE QUESTIONS OR CONCERNS CONTACT FORT MILLER FAB3
(518)-584-4400 or www.fmfab3.com

****IMPORTANT SAFETY INFORMATION****

General Ladder Safety For Side Mounted Ladders (If equipped)

⚠️ WARNING A WARNING SYMBOL INDICATES A HAZARDOUS SITUATION WHICH, IF NOT AVOIDED, COULD RESULT IN SERIOUS INJURY OR DEATH

There are potential hazards that are associated with side-mounted ladders. Care must be taken while using these ladders. Following these basic guidelines and good COMMON SENSE can help prevent accidents. At any time are you unsure, please ask your supervisor.

⚠️ WARNING ALWAYS

- Thoroughly inspect the ladder prior to use. Inspect for missing or damaged components and loose fasteners. DO NOT use if not in good working order. See your Supervisor for corrective actions.
- Use a three-point method in mounting and dismounting equipment. When mounting, face the equipment, using both hands, firmly grasp the handhold while placing one foot solidly on the step and proceeding upward on the ladder. When dismounting, face the equipment, using both hands, firmly grasp the handhold while placing one foot solidly on the step and proceeding downward on the ladder.
- Keep body centered on the ladder. DO NOT overreach.
- Use all steps and handholds provided when mounting or dismounting the equipment.
- Keep steps as clean as possible.
- Park in an area that provides maximum protection for the operator and passenger. Ensure a safe, solid landing area for mounting and dismounting the equipment.
- Shut off engine and set the parking brake prior to use of the ladder.

⚠️ WARNING NEVER

- Jump from equipment
- Leave equipment unattended with the engine running.
- “NO RIDERS” DO NOT ride on the equipment at any time.
- Keep the ladder in the “up” position except when in use.

MAINTENANCE

- Be sure that the hinge assembly is lubricated on a regular basis with a light weight oil. The ny-lock nuts and bolts should be “snug” to allow the ladder to pivot freely. Inspect the nuts and bolts for wear and replace as needed.
- The rubber Jeep catch to lock the ladder in the “up” position after time becomes weather checked and the rubber may deteriorate. Inspect the Jeep catch weekly and replace as needed.

FOR WARNING/NOTICE DECALS THAT ARE MISSING OR NOT LEGIBLE, OR FOR MANUAL REPLACEMENT COPIES, OR IF YOU HAVE QUESTIONS OR CONCERNS CONTACT FORT MILLER FAB3

(518)-584-4400 or www.fmfab3.com

****IMPORTANT SAFETY INFORMATION****

CAUSES OF A EQUIPMENT ROLL OVER

⚠ WARNING A WARNING SYMBOL INDICATES A HAZARDOUS SITUATION WHICH, IF NOT AVOIDED, COULD RESULT IN SERIOUS INJURY OR DEATH



- ⚠ WARNING** Never dump or drive equipment on uneven ground.
- ⚠ WARNING** Keep dump body free of material build up, that can result in an unbalanced load.
- ⚠ WARNING** Material should be centered in the dump body while loading, before being transported, or dumped.
- ⚠ WARNING** Ensure equipment is in good working condition before each use.
- ⚠ WARNING** The inside of the dump body should be smooth and free of holes.
- ⚠ WARNING** Material can freeze in the winter if stored in the dump body causing load to be unbalanced.
- ⚠ WARNING** Avoid dumping too close to the edge of the area that is being filled.
- ⚠ WARNING** Ensure the tailgate is unlatched before raising the dump body.
- ⚠ WARNING** Allow truck to move forward slightly while dumping.
- ⚠ WARNING** Immediately lower dump body if any leaning occurs during the dumping process.
- ⚠ WARNING** No one should be beside of the truck while dumping.
- ⚠ WARNING** Watch for obstacles above the truck including but not limited to utility wires and branches.
- ⚠ WARNING** Always stay alert and pay close attention to the surrounding area while driving or operating this equipment.

*****FOR WARNING/NOTICE DECALS THAT ARE MISSING OR NOT LEGIBLE, OR FOR MANUAL REPLACEMENT COPIES, OR IF YOU HAVE QUESTIONS OR CONCERNS CONTACT FORT MILLER FAB3*****

(518)-584-4400 or www.fmfab3.com

TARCO® T-4000

TABLE OF CONTENTS

Cover Page	*
Important Safety Information	1
Table of Contents	12
T-4000	13
Lights	14
Prop Location	18
Decal Location	19
Decal Identification	23

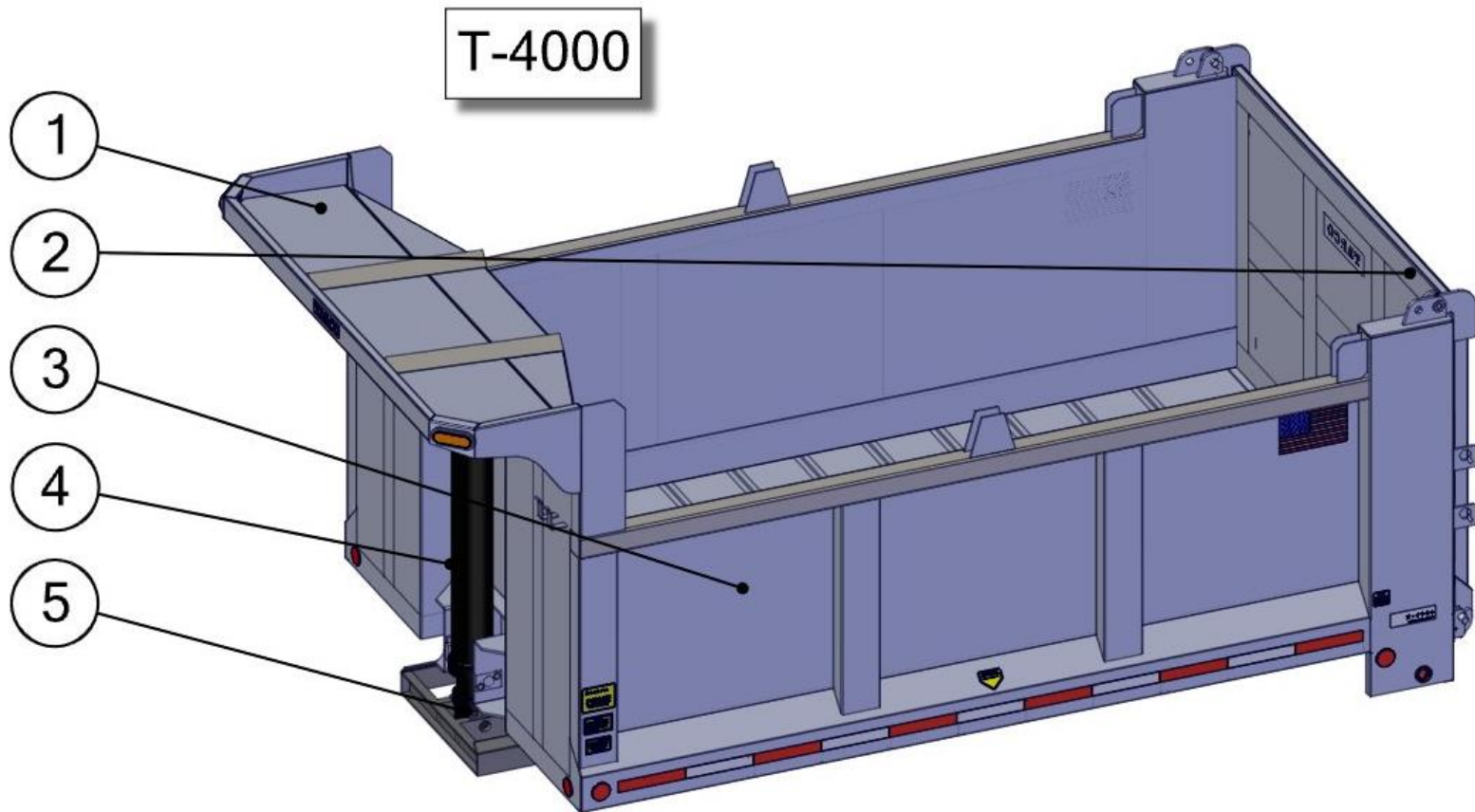

BOM ID	Description	Qty
1	CAB SHIELD	1
2	TAILGATE	1
3	T-4000 ASSEMBLY	1

BOM ID	Description	Qty
4	LIFT CYLINDER	1
5	H-FRAME	1

LIGHTS

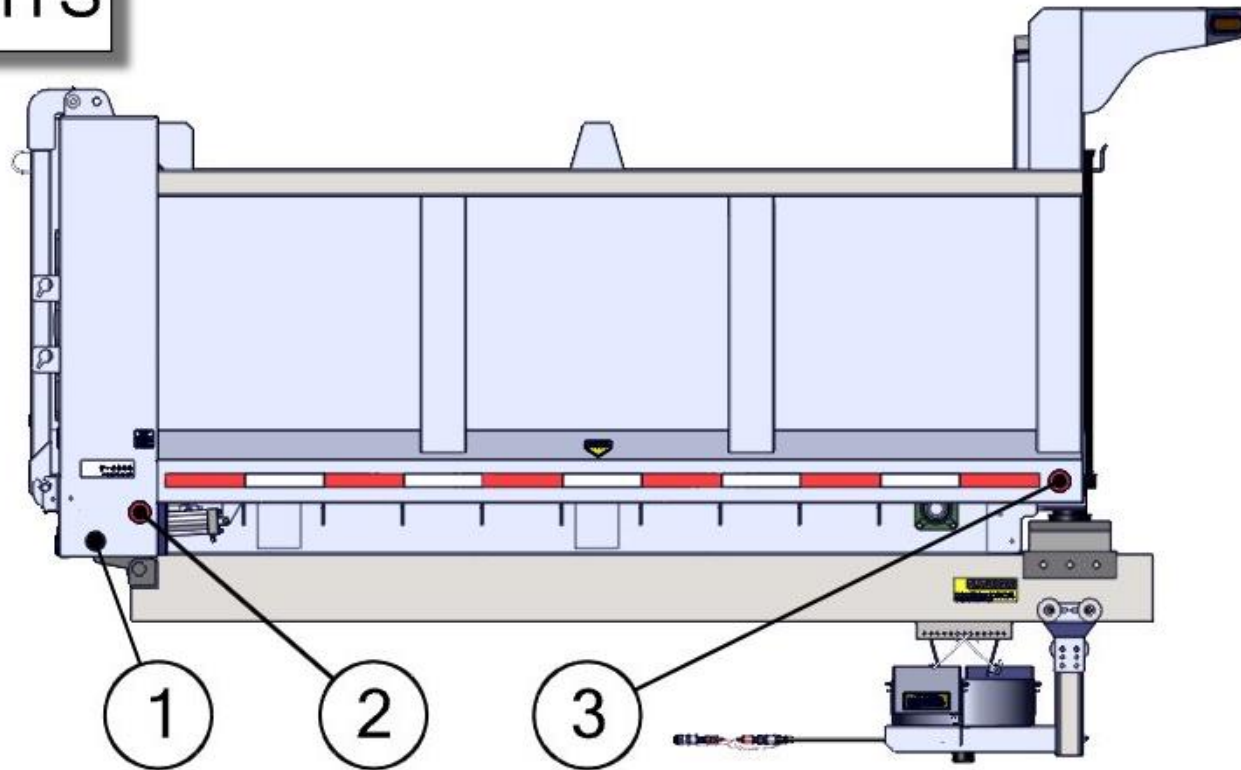

BOM ID	JDENumber (config)	Description (config)	Qty
1	27472	RED LIGHT	1
2	28043	REFLECTOR - RED	1
3	28044	REFLECTOR - AMBER	1

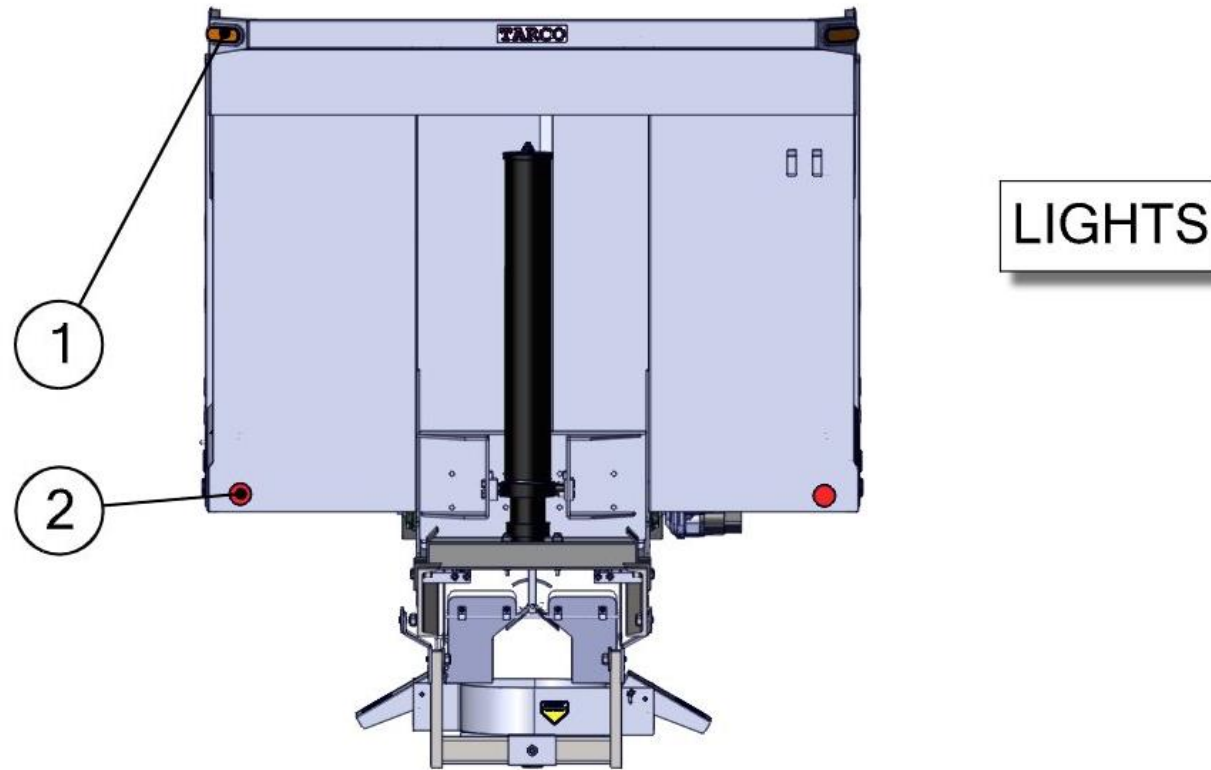

BOM ID	JDENumber (config)	Description (config)	Qty
1	28019	LIGHT STROBE - AMBER	2
2	28044	REFLECTOR - AMBER	2

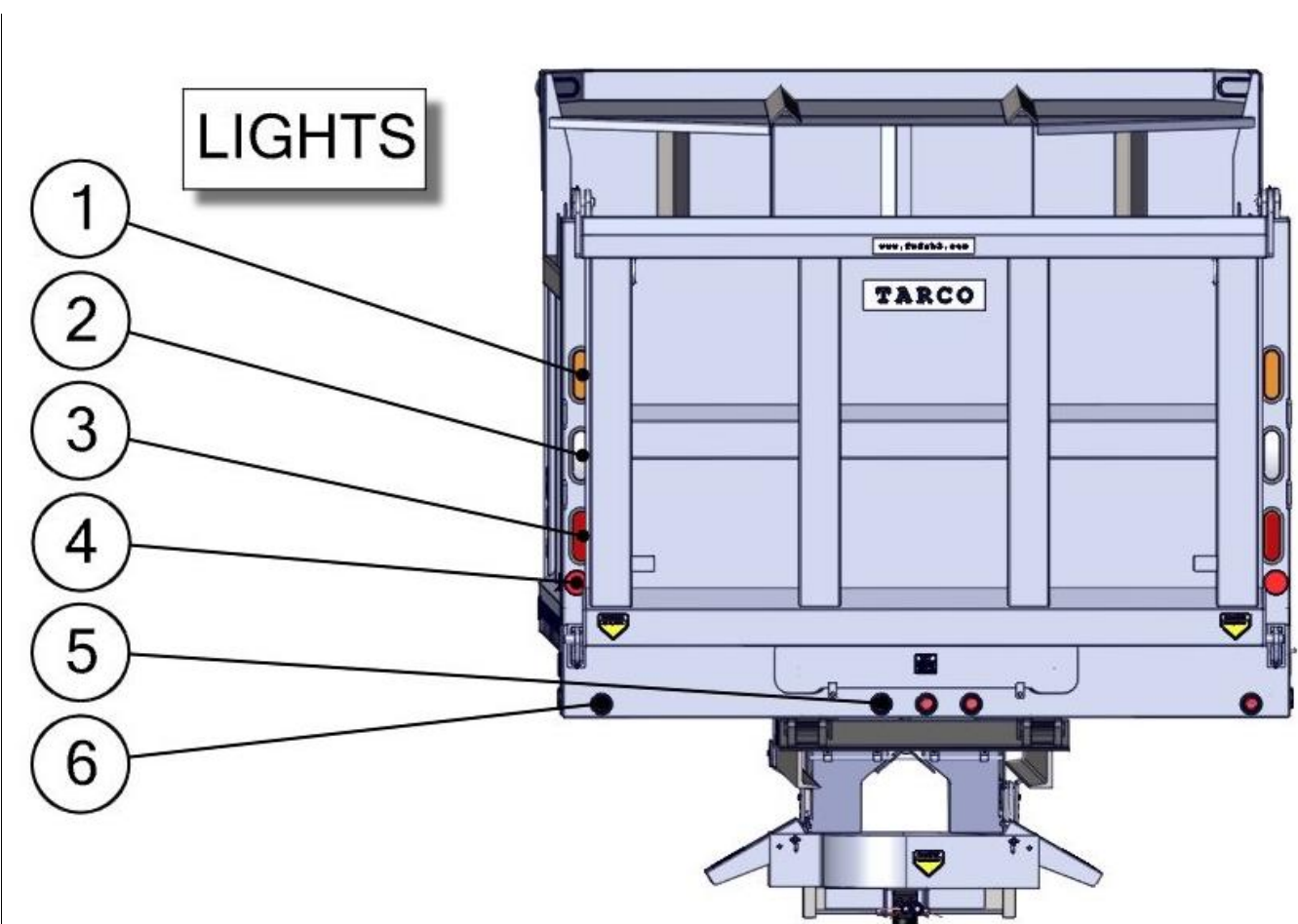

BOM ID	JDENumber (config)	Description (config)	Qty
1	28019	LIGHT STROBE - AMBER	2
2	28020	LIGHT BACK UP	2
3	33115	LIGHT OVAL RED	2
4	28043	REFLECTOR - RED	2
5	27472	RED LIGHT	4
6	32824	LIGHT, 2" LED RED	1

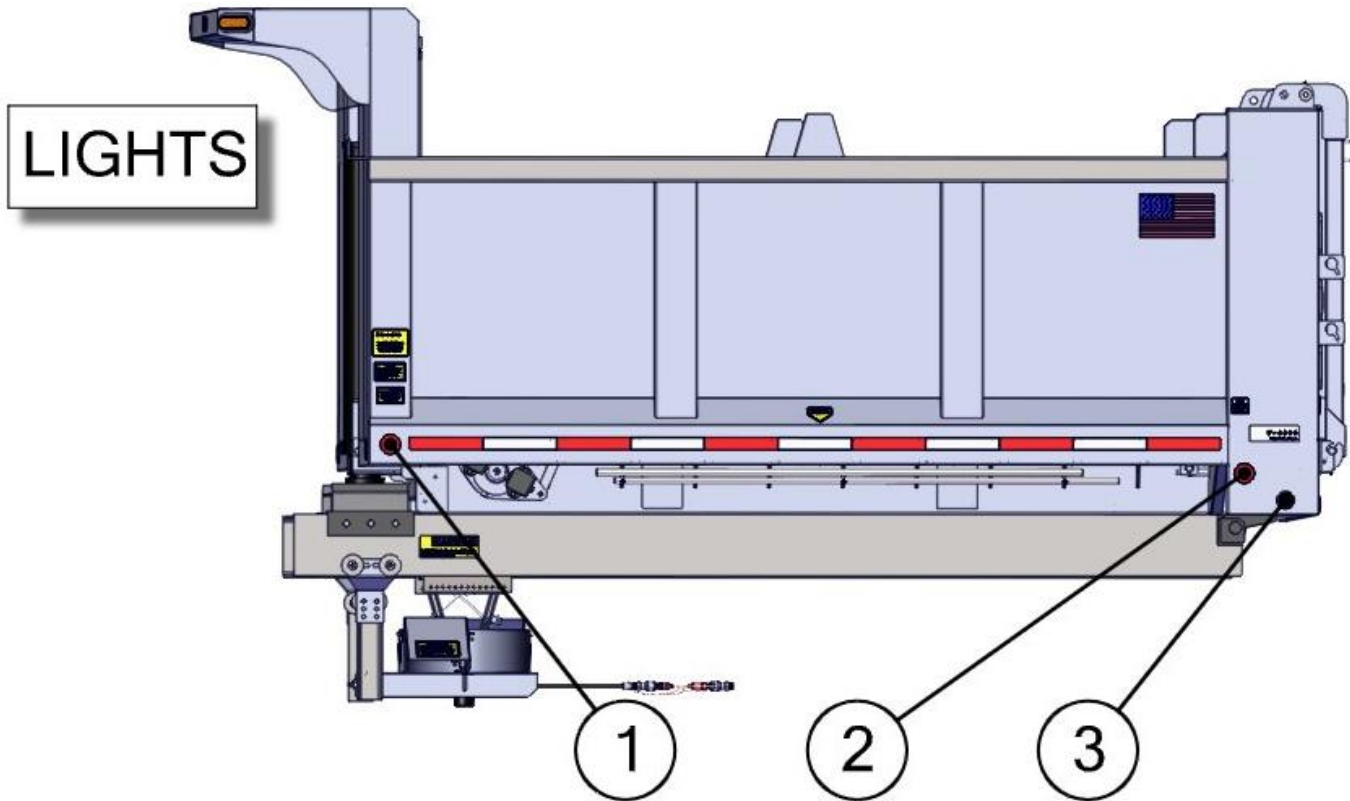

BOM ID	JDENumber (config)	Description (config)	Qty
1	28044	REFLECTOR - AMBER	1
2	28043	REFLECTOR - RED	1
3	27472	RED LIGHT	1



*****DO NOT GO UNDER DUMP BOX UNLESS BOX IS EMPTY AND PROPS ARE SECURED IN THE LOCKED OPEN POSITION*****



A WARNING SYMBOL INDICATES A HAZARDOUS SITUATION WHICH, IF NOT AVOIDED, COULD RESULT IN SERIOUS INJURY OR DEATH.

IF THE BODY LOWERS AND THE PROPS ARE NOT LOCKED IN PLACE ANY PERSON UNDER IT COULD BE CRUSHED TO DEATH OR HAVE SERIOUS INJURIES AS A RESULT.

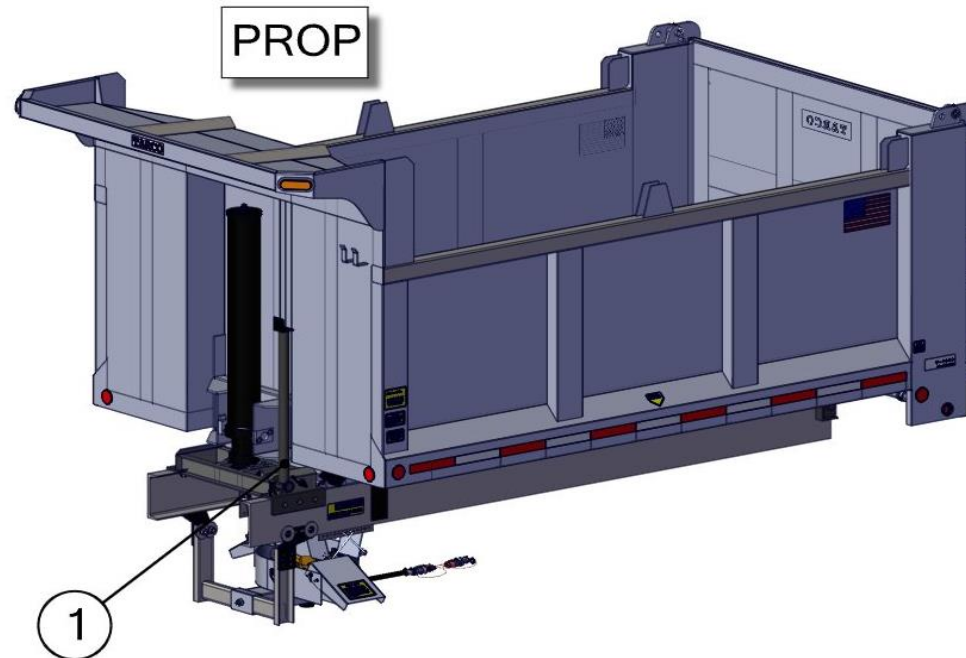

BOM ID	Description	Qty
1	Dump Body Prop	1

DECALS

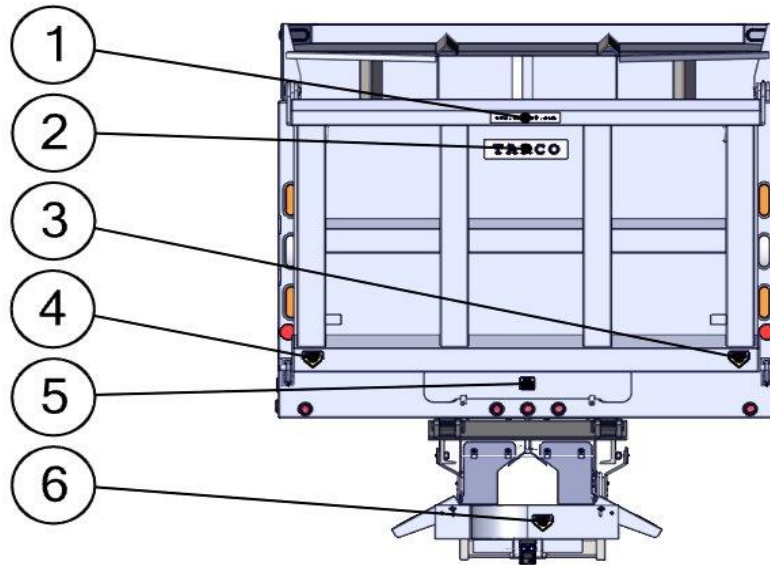

BOM ID	JDENumber (config)	Description (config)	Qty
1	29761	DECAL - WWW.FMFAB3.COM	1
2	27585	DECAL-TARCO	1
3	27561	DECAL-DANGER-KEEP HANDS AND	1
4	27561	DECAL-DANGER-KEEP HANDS AND	1
5	27507	DECAL - SAFETY FIRST	1
6	27561	DECAL-DANGER-KEEP HANDS AND	1

DO NOT OPERATE EQUIPMENT IF ANY DECALS THAT CAME WITH THE PRODUCT OR WERE LATER SENT TO YOU BY FORT MILLER FAB3 ARE MISSING OR DAMAGED. THE ABOVE DIAGRAM ILLUSTRATES THE LOCATION AND NATURE OF THE WARNINGS THAT MUST BE ON THE PRODUCT: TO OBTAIN REPLACEMENT DECALS THAT ARE MISSING OR DAMAGED CONTACT FORT MILLER FAB3 AT (518)584-4400 OR WWW.FMFAB3.COM

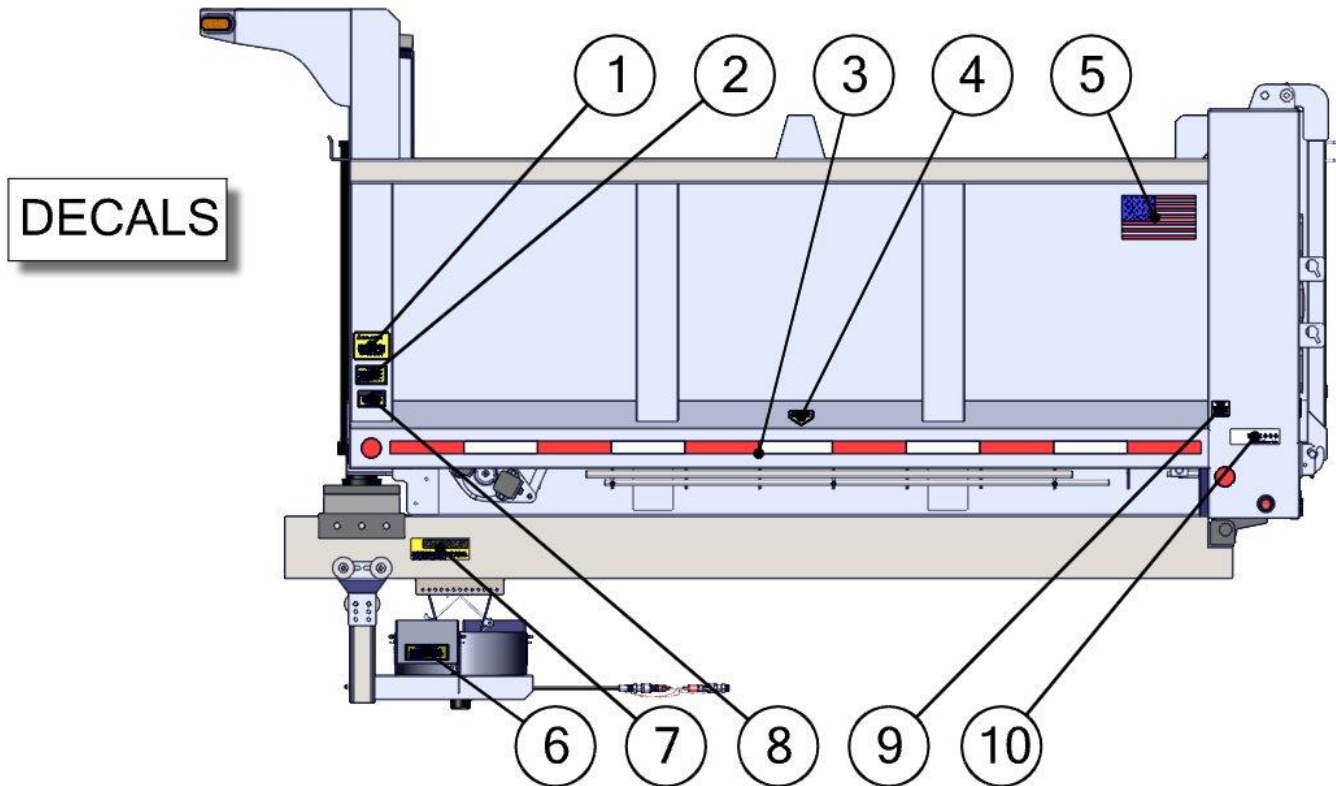

DECALS

BOM ID	JDENumber (config)	Description (config)	Qty
1	27712	DECAL - DO NOT CLIMB OR WORK	1
2	27542	DECAL-DANGER BEFORE	1
3	28318	TAPE-CONSPICUITY 2" WIDE	1
4	27561	DECAL-DANGER-KEEP HANDS AND	1
5	27571	DECAL - AMERICAN FLAG	1
6	27546	DECAL - WARNING DANGER STAY	1

BOM ID	JDENumber (config)	Description (config)	Qty
7	27499	CAUTION SAFETY PROP DECAL	1
8	27569	DECAL-WARNING FAILURE TO FOLLOW	1
9	27507	DECAL - SAFETY FIRST	1
10	36195	Decal "T-4000",	1

DO NOT OPERATE EQUIPMENT IF ANY DECALS THAT CAME WITH THE PRODUCT OR WERE LATER SENT TO YOU BY FORT MILLER FAB3 ARE MISSING OR DAMAGED. THE ABOVE DIAGRAM ILLUSTRATES THE LOCATION AND NATURE OF THE WARNINGS THAT MUST BE ON THE PRODUCT: TO OBTAIN REPLACEMENT DECALS THAT ARE MISSING OR DAMAGED CONTACT FORT MILLER FAB3 AT (518)584-4400 OR WWW.FMFAB3.COM

DECALS

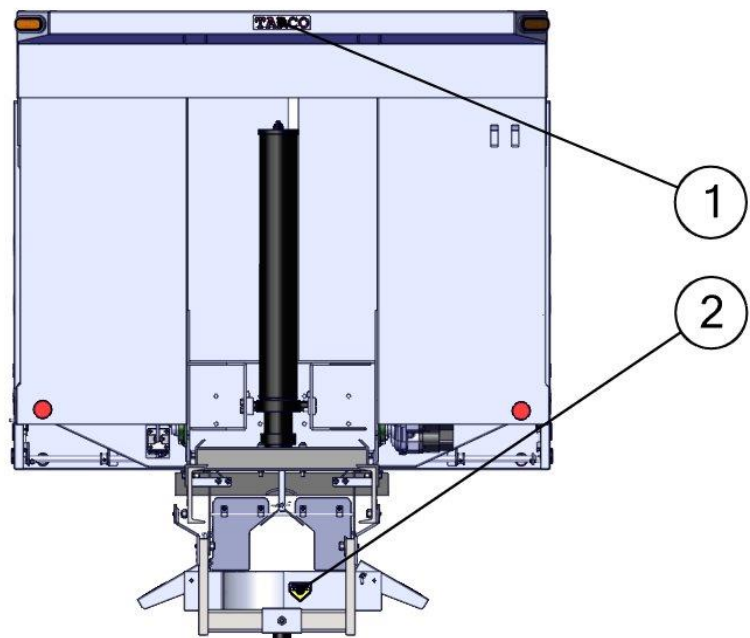

BOM ID	JDENumber (config)	Description (config)	Qty
1	27492	Decal - Tarco	1
2	27561	Decal - Danger - Keep Hand and	1

DO NOT OPERATE EQUIPMENT IF ANY DECALS THAT CAME WITH THE PRODUCT OR WERE LATER SENT TO YOU BY FORT MILLER FAB3 ARE MISSING OR DAMAGED. THE ABOVE DIAGRAM ILLUSTRATES THE LOCATION AND NATURE OF THE WARNINGS THAT MUST BE ON THE PRODUCT: TO OBTAIN REPLACEMENT DECALS THAT ARE MISSING OR DAMAGED CONTACT FORT MILLER FAB3 AT (518)584-4400 OR WWW.FMFAB3.COM

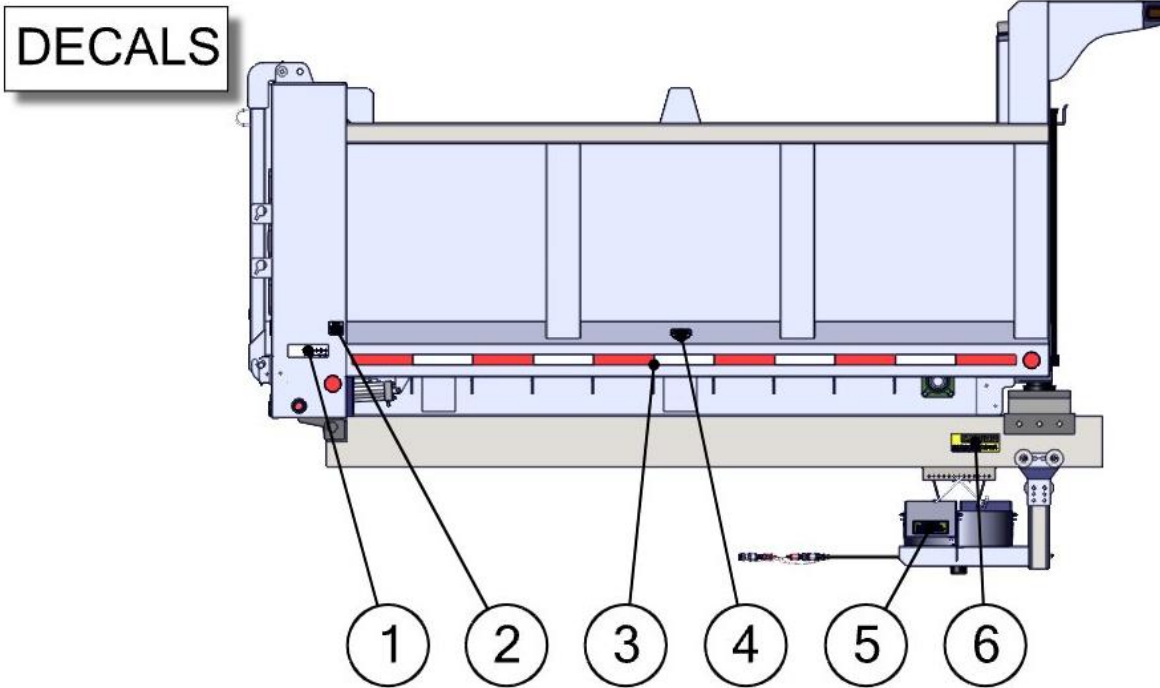

BOM ID	JDENumber (config)	Description (config)	Qty
1	36195	DECAL "T-4000"	1
2	27507	DECAL - SAFETY FIRST	1
3	28318	TAPE-CONSPICUITY 2" WIDE	1
4	27561	DECAL-DANGER-KEEP HANDS AND	1
5	27546	DECAL- WARNING DANGER STAY	1
6	27499	CAUTION SAFETY PROP DECAL	1

DO NOT OPERATE EQUIPMENT IF ANY DECALS THAT CAME WITH THE PRODUCT OR WERE LATER SENT TO YOU BY FORT MILLER FAB3 ARE MISSING OR DAMAGED. THE ABOVE DIAGRAM ILLUSTRATES THE LOCATION AND NATURE OF THE WARNINGS THAT MUST BE ON THE PRODUCT: TO OBTAIN REPLACEMENT DECALS THAT ARE MISSING OR DAMAGED CONTACT FORT MILLER FAB3 AT (518)584-4400 OR WWW.FMFAB3.COM

DECAL IDENTIFICATION

TARCO

JDE# 27492 (7500-14) QTY=1

COMPANY BRAND

LOCATION DETAIL SEE PAGE 21 ITEM 1



JDE# 27499 (7500-31) QTY=2

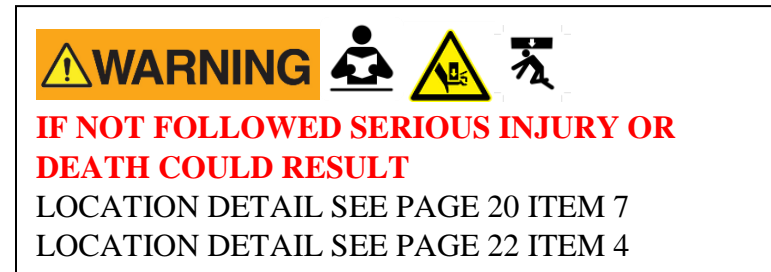



JDE# 27507 (7500-36) QTY=3



JDE# 27542 (7500-43) QTY=1

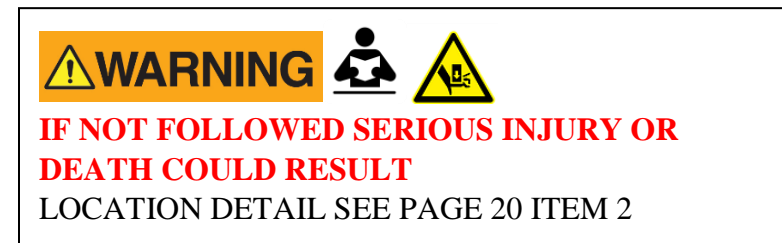
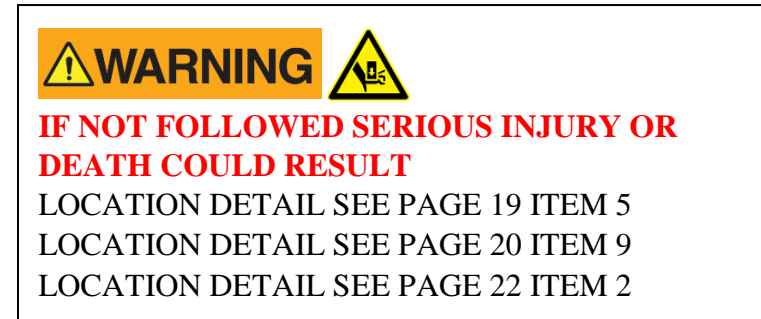



JDE# 27546 (7500-45) QTY=2



JDE# 27561 (7500-87) QTY=6

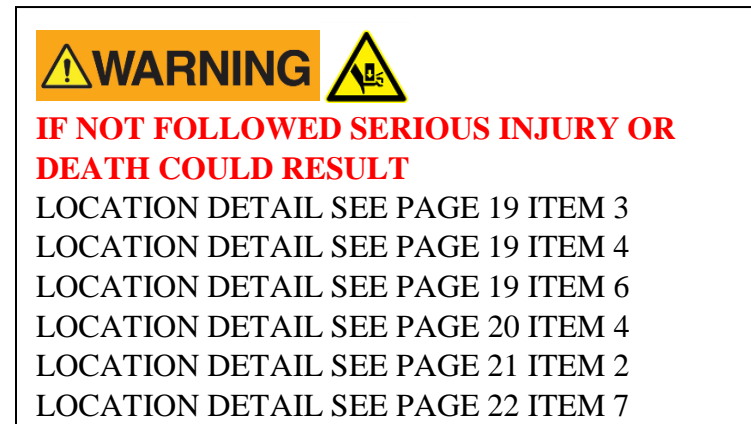
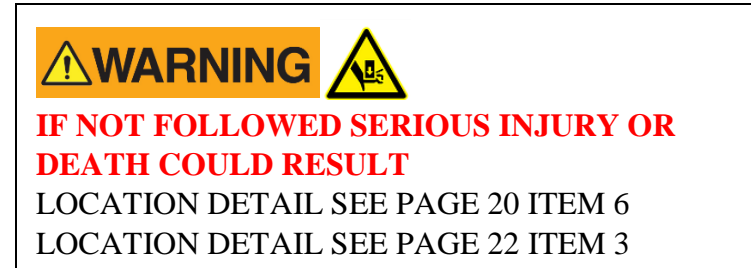



JDE# 27569 (7500-89) QTY=1

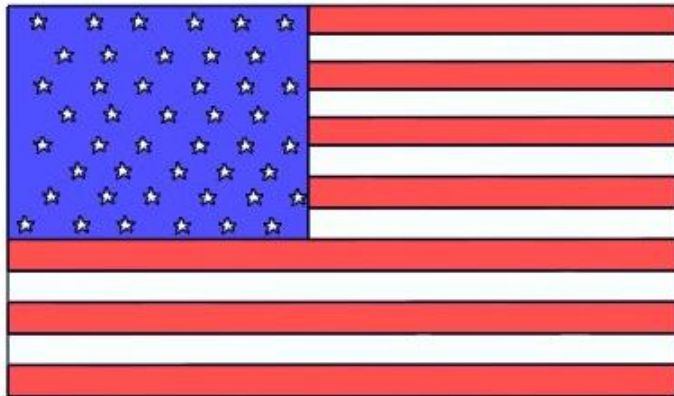

JDE# 27571 (7500-90) QTY=1



TARCO

COMPANY BRAND

LOCATION DETAIL SEE PAGE 19 ITEM 2

JDE# 27585 (7500-94) QTY=1



JDE# 27712 (7500-97) QTY=1

www.fmfab3.com

JDE# 29761 (7500-101) QTY=1



JDE# 28318 (60033-56) QTY=2

T - 4000

All Season Dump Body

JDE# 36195 (36195) QTY=2

CONTACT INFORMATION

LOCATION DETAIL SEE PAGE 19 ITEM 1

⚠ CAUTION

USE CAUTION POTENTIAL HAZARD

LOCATION DETAIL SEE PAGE 20 ITEM 3

LOCATION DETAIL SEE PAGE 22 ITEM 6

MACHINE NAME

LOCATION DETAIL SEE PAGE 20 ITEM 10

LOCATION DETAIL SEE PAGE 22 ITEM 5