

****KEEP THIS MANUAL****

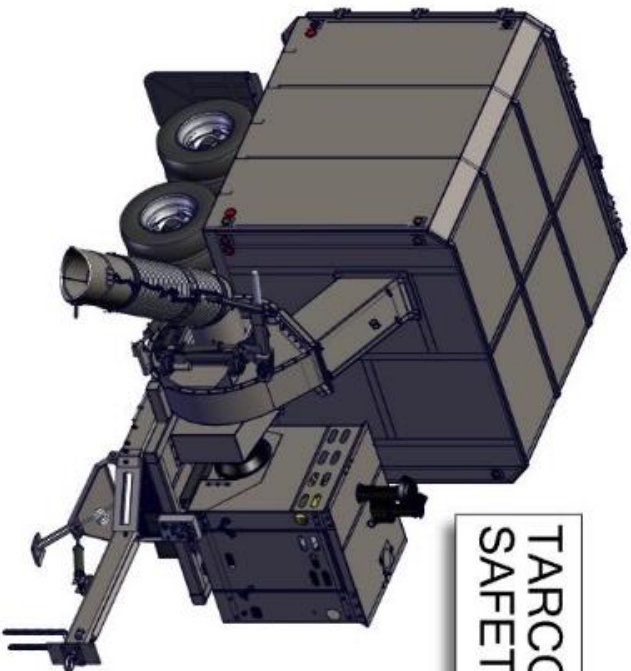

**TARCO® HURRICANE
SAFETY MANUAL**



FORT MILLER FAB3 CORP.
678 WILBUR AVE.
GREENWICH, NY 12834
www.fmfab3.com
TEL. 518-584-4400
FAX. 518-584-6630

**WARNING**

Read and understand operator's manual before using this equipment.
Failure to follow operating instructions could result in death or serious injury.

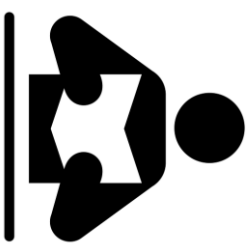

****IMPORTANT SAFETY INFORMATION****



Thank you and congratulations on your recent purchase.
Please take time reading and understanding the manual before operating the equipment.
Fill in the following information, so that it is at hand when needed.

MODEL _____
SERIAL NO. _____
DATE OF PURCHASE _____



*****The operator must carefully read and follow any warnings, safety sign and instructions provided with or located on the equipment.*****

*****Please keep a copy of the manual in the cab so that it may be consulted by the operator.*****





*****Do not allow untrained operators to use this equipment as serious injury, death or equipment damage could result.*****

FOR WARNING/NOTICE DECALS THAT ARE MISSING OR NOT LEGIBLE, OR FOR MANUAL REPLACEMENT COPIES, OR IF YOU HAVE QUESTIONS OR CONCERNS CONTACT FORT MILLER FAB3
(518)-584-4400 or www.fmfab3.com

****IMPORTANT SAFETY INFORMATION****

SIGNAL WORDS & DEFINITIONS

SYMBOLS USED IN THE MANUAL AND ON THE MACHINERY

	SAFETY ALERT SYMBOL USED TO ALERT OF POTENTIAL PERSONAL INJURY HAZARDS. OBEY ALL SAFETY MESSAGES THAT FOLLOW THIS SYMBOL TO AVOID POSSIBLE INJURY OR DEATH.
	DANGER INDICATES A HAZARDOUS SITUATION WHICH, IF NOT AVOIDED, WILL RESULT IN DEATH OR SERIOUS INJURY.
	WARNING INDICATES A HAZARDOUS SITUATION WHICH, IF NOT AVOIDED, COULD RESULT IN DEATH OR SERIOUS INJURY.
	CAUTION USED WITH THE SAFETY ALERT SYMBOL, INDICATES A HAZARDOUS SITUATION WHICH, IF NOT AVOIDED, COULD RESULT IN MINOR OR MODERATE INJURY.
	NOTICE IS USED TO ADDRESS PRACTICES NOT RELATED TO PERSONAL INJURY.

*****FOR WARNING/NOTICE DECALS THAT ARE MISSING OR NOT LEGIBLE, OR FOR MANUAL REPLACEMENT COPIES, OR IF YOU HAVE QUESTIONS OR CONCERNS CONTACT FORT MILLER FAB3*****

(518)-584-4400 or www.fmfab3.com

****IMPORTANT SAFETY INFORMATION****



A WARNING SYMBOL INDICATES A HAZARDOUS SITUATION WHICH, IF NOT AVOIDED, COULD RESULT IN SERIOUS INJURY OR DEATH.

- **⚠ WARNING** DO NOT OPERATE MACHINERY WITHOUT READING AND UNDERSTANDING THIS MANUAL. **FAILURE TO FOLLOW THIS INFORMATION CAN LEAD TO MACHINE DAMAGE, SERIOUS INJURY, OR EVEN DEATH.**
- **⚠ WARNING** USE ALL MACHINERY FOR ITS INTENDED USE. **FAILURE TO FOLLOW THIS INFORMATION CAN LEAD TO MACHINE DAMAGE, SERIOUS INJURY, OR EVEN DEATH.**
- **⚠ WARNING** DO NOT MODIFY EQUIPMENT. **FAILURE TO FOLLOW THIS INFORMATION CAN LEAD TO MACHINE DAMAGE, SERIOUS INJURY, OR EVEN DEATH.**
- **⚠ WARNING** ANY MISS USE OR MODIFICATION TO THE EQUIPMENT **CAN LEAD TO MACHINE DAMAGE, SERIOUS INJURY, OR EVEN DEATH.**
- **⚠ WARNING** DO NOT RIDE ON MACHINERY. **FAILURE TO FOLLOW THIS INFORMATION CAN LEAD TO MACHINE DAMAGE, SERIOUS INJURY, OR EVEN DEATH.**

FOR WARNING/NOTICE DECALS THAT ARE MISSING OR NOT LEGIBLE, OR FOR MANUAL REPLACEMENT COPIES, OR IF YOU HAVE QUESTIONS OR CONCERNS CONTACT FORT MILLER FAB3
(518)-584-4400 or www.fmfab3.com

****IMPORTANT SAFETY INFORMATION****

IMPORTANT SAFETY INFORMATION

TO THE OPERATOR

Prior to using the TARCO® HURRICANE, you must be properly trained in the full operation of the machine. This would include but not be limited to a complete review of the operating and safety manual and a complete understanding of all safety procedures including the safety decals and information on the machine. If there is something you do not understand, ask your supervisor to explain it to you. If you require additional manuals or decals, please contact your dealer or the manufacturer.

Make sure all the manufacturers' protective guards, shields, and screens are in good repair, in place, and securely fastened. Damaged, missing, or weakened safety components can create a hazardous situation for the operator. NEVER remove or modify any safety components on this equipment.

Wear all the protective clothing and personal safety devices issued to you or called for by the job conditions. This may include but is not limited to hard hat, safety shoes, safety glasses or goggles, heavy gloves, hearing protection, reflective clothing or wet weather gear. Remember, you are responsible for your safety and that of your co-workers. Good safety practices protect you and the people around you.

NEVER ride on any part of the equipment or trailer when operating the machine or at any time. Never modify the machine for riders in any way. Prior to operating this machine, be certain that all operators can ride safely in the truck or vehicle being used to trailer the machine. If your machine has been altered to accommodate riders, remove these alterations immediately as this can result in serious injury or death. A "NO RIDERS" decal should be in place. Please request these from your dealer or use the web to request them from Fort Miller FAB3 Corp. (518)-584-4400 or www.fmfab3.com.

****IMPORTANT SAFETY INFORMATION****



A WARNING SYMBOL INDICATES A HAZARDOUS SITUATION WHICH, IF NOT AVOIDED, COULD RESULT IN SERIOUS INJURY OR DEATH



⚠ WARNING DO NOT operate unit without wearing proper safety equipment as described in this manual.

⚠ WARNING DO NOT operate, maintain or repair this unit without fully reading and understanding ALL aspects of this manual.

⚠ WARNING DO NOT lubricate, make any adjustment or repairs before proper LOCK OUT/TAG OUT is performed.

⚠ WARNING DO NOT operate the unit while under the influence of alcohol, drugs, or any medication that could impair operating abilities.

⚠ WARNING DO NOT operate the unit with ANY guards or safety devices broken, missing, or inoperable.

⚠ WARNING DO NOT operate the unit without fully inspecting the unit for any damage or leakage.

⚠ WARNING DO NOT use equipment that is not safe.

⚠ WARNING DO NOT operate the unit if all operating controls and safety devices are not in good working order.

⚠ WARNING DO NOT operate unit in a state of disrepair.

⚠ WARNING DO NOT ride, sit or stand on the unit while in use.

⚠ WARNING DO NOT place hands or feet near moving or rotating parts.

FOR WARNING/NOTICE DECALS THAT ARE MISSING OR NOT LEGIBLE, OR FOR MANUAL REPLACEMENT COPIES, OR IF YOU HAVE QUESTIONS OR CONCERNS CONTACT FORT MILLER FAB3
(518)-584-4400 or www.fmfab3.com

****IMPORTANT SAFETY INFORMATION****

- ⚠ WARNING** DO NOT jump from the vehicle.
- ⚠ WARNING** DO NOT allow personnel to ride anywhere, except in the cab, when the unit or vehicle is in operation.
- ⚠ WARNING** DO NOT modify the unit for any reason to allow for riders.
- ⚠ WARNING** DO NOT exceed weight limitations.
- ⚠ WARNING** DO NOT smoke or weld near the unit.
- ⚠ WARNING** DO NOT leave machine running unattended.
- ⚠ WARNING** DO NOT park unit on a steep grade or slope.
- ⚠ WARNING** DO NOT operate the unit until all hydraulic components are checked for leaks and damage, and repaired if found.
- ⚠ WARNING** DO NOT tow the unit without attaching all the safety chains and the breakaway cable.
- ⚠ WARNING** DO NOT tow the unit with a damaged tongue.
- ⚠ WARNING** DO NOT fill the fuel tank with the engine running. Allow engine to cool before refueling.
- ⚠ WARNING** DO NOT operate the unit if fuel is spilled or with cap off.
- ⚠ WARNING** DO NOT run the engine in an enclosed area.
- ⚠ WARNING** DO NOT operate engine with an accumulation of combustible material on or around the engine.
- ⚠ WARNING** DO NOT run engine with air cleaner removed.
- ⚠ WARNING** DO NOT operate the unit if there is excessive vibration, shut down and repair immediately.
- ⚠ WARNING** DO NOT go under a raised dump body unless it is empty and all props are locked in place.

FOR WARNING/NOTICE DECALS THAT ARE MISSING OR NOT LEGIBLE, OR FOR MANUAL REPLACEMENT COPIES, OR IF YOU HAVE QUESTIONS OR CONCERNS CONTACT FORT MILLER FAB3
(518)-584-4400 or www.fmfab3.com

****IMPORTANT SAFETY INFORMATION****

- ⚠ WARNING** DO NOT lock props in place until dump body is empty.
- ⚠ WARNING** DO NOT raise dump body near any power lines or low tree branches.
- ⚠ WARNING** DO NOT raise dump body on an uneven or soft surface.
- ⚠ WARNING** DO NOT lower dump body without a complete visual check of the body area.
- ⚠ WARNING** DO NOT unload or load on uneven surfaces.
- ⚠ WARNING** DO NOT lift both the dump body and floor at the same time.
- ⚠ WARNING** DO NOT operate on recently excavated ground or in filling ground if the soil was not properly compacted.
- ⚠ WARNING** DO NOT stand in the cylinders operation area when in action.
- ⚠ WARNING** DO NOT stand in the area of outflow.
- ⚠ WARNING** DO NOT operate the truck with a defective back up alarm. Fix immediately if defective.
- ⚠ WARNING** DO NOT operate the truck with a defective body up indicator light. Fix immediately if defective.
- ⚠ WARNING** DO NOT work under a raised dump body unless it is empty and all props are locked in place.

FOR WARNING/NOTICE DECALS THAT ARE MISSING OR NOT LEGIBLE, OR FOR MANUAL REPLACEMENT COPIES, OR IF YOU HAVE QUESTIONS OR CONCERNS CONTACT FORT MILLER FAB3
(518)-584-4400 or www.fmfab3.com

****IMPORTANT SAFETY INFORMATION****



A WARNING SYMBOL INDICATES A HAZARDOUS SITUATION WHICH, IF NOT AVOIDED, COULD RESULT IN SERIOUS INJURY OR DEATH



- ⚠ WARNING** DO wear proper safety equipment as described in this manual.
- ⚠ WARNING** DO completely read and understand the owner's manual before operating, maintaining, or repairing this equipment.
- ⚠ WARNING** DO perform proper LOCK OUT/TAG OUT before any adjustment or repairs are made.
- ⚠ WARNING** DO remove the negative battery cable before doing any maintenance on the unit.
- ⚠ WARNING** DO follow and obey ALL safety regulations.
- ⚠ WARNING** DO replace any worn or missing safety decals immediately contact: (518)584-4400 or at www.fmfab3.com
- ⚠ WARNING** DO completely inspect the unit before leaving the service garage.
- ⚠ WARNING** DO watch for pedestrians, animals, and other foreign objects when operating this unit.
- ⚠ WARNING** DO check the tow tongue before each use for cracks.
- ⚠ WARNING** DO check the impeller, liners and blower housing for cracks and holes daily. Replace if necessary.
- ⚠ WARNING** DO watch for pedestrians, animals and other foreign material while vacuuming leaves.
- ⚠ WARNING** DO wear proper safety equipment as described in this manual.

*****FOR WARNING/NOTICE DECALS THAT ARE MISSING OR NOT LEGIBLE, OR FOR MANUAL REPLACEMENT COPIES, OR IF YOU HAVE QUESTIONS OR CONCERNS CONTACT FORT MILLER FAB3***
(518)-584-4400 or www.fmfab3.com**

****IMPORTANT SAFETY INFORMATION****

- ⚠ WARNING DO** watch for pedestrians, animals and other foreign material while vacuuming leaves.
- ⚠ WARNING DO** check the impeller, liners and blower housing for cracks and holes daily. Replace if necessary.
- ⚠ WARNING DO** inspect and be attentive to what is being vacuumed.
- ⚠ WARNING DO** follow engine manufactures operating and maintenance instructions.
- ⚠ WARNING DO** check fuel lines and fittings frequently for cracks or leaks. Replace if necessary.
- ⚠ WARNING DO** insert the body props before going under the raised body for any reason.
- ⚠ WARNING DO** observe for any overhead obstructions prior to dumping.
- ⚠ WARNING DO** make sure the opening control of rear gate is in the closed position when truck is moving.
- ⚠ WARNING DO** make sure the truck is in a stable position on level ground before starting to lift the dump body.
- ⚠ WARNING DO** at all time be in control of the operation when out flowing.
- ⚠ WARNING DO** make sure the rear tailgate is free before starting to lift the dump body.
- ⚠ WARNING DO** make sure that when the dump body is not in operation that it is laying on the truck's frame before driving
- ⚠ WARNING DO** make sure the truck is empty before locking the safety props.
- ⚠ WARNING DO** use a spotter when backing.

FOR WARNING/NOTICE DECALS THAT ARE MISSING OR NOT LEGIBLE, OR FOR MANUAL REPLACEMENT COPIES, OR IF YOU HAVE QUESTIONS OR CONCERNS CONTACT FORT MILLER FAB3

(518)-584-4400 or www.fmfab3.com

****IMPORTANT SAFETY INFORMATION****



A WARNING SYMBOL INDICATES A HAZARDOUS SITUATION WHICH, IF NOT AVOIDED, COULD RESULT IN SERIOUS INJURY OR DEATH

⚠️ WARNING – Before starting the engine or applying power to the machine be sure the suction assembly is securely in place over the suction and discharge openings and ready for operation. Make sure all safety interlock switches are properly contacted and in good working order. Make sure the belt guard is properly secured. **NEVER** place any part of your body or clothing near the suction opening, engine, or belt guard. **SERIOUS PERSONAL INJURY OR DEATH COULD RESULT BY NOT FOLLOWING PROPER SAFETY PRECAUTIONS.**

⚠️ WARNING – All safety interlock switches must be tested before each use to ensure interlock switches are in proper working order. Do not operate this machinery if interlock switches are not working correctly, lock this machine out and repair or replace interlock switch before use. **SERIOUS PERSONAL INJURY OR DEATH COULD RESULT FROM AN IMPROPERLY WORKING SAFETY INTERLOCK SWITCH.**

⚠️ WARNING – Should the machine develop excessive vibration during operation, immediately shut the machine down and do not restart the machine until the cause of the vibration has been identified and corrected. **NOT FOLLOWING THIS PROCEDURE COULD RESULT IN SERIOUS PERSONAL INJURY OR DEATH.**

⚠️ WARNING – Under no circumstances any safety interlock switch be tampered with, bypassed or disabled. ALL Safety interlock switches are to be maintained and in proper working order. **SERIOUS PERSONAL INJURY OR DEATH COULD RESULT FROM IMPROPER SAFETY INTERLOCK SWITCH MAINTENANCE.**

FOR WARNING/NOTICE DECALS THAT ARE MISSING OR NOT LEGIBLE, OR FOR MANUAL REPLACEMENT COPIES, OR IF YOU HAVE QUESTIONS OR CONCERNS CONTACT FORT MILLER FAB3

(518)-584-4400 or www.fmfab3.com

****IMPORTANT SAFETY INFORMATION****

⚠️WARNING – Never disconnect any suction assembly or get near the suction case inlet opening without first completely stopping the suction impeller, shutting down and positively locking out the power source. **NOT FOLLOWING THESE PROCEDURES COULD RESULT IN SERIOUS PERSONAL INJURY OR DEATH.**

⚠️WARNING – Never inspect or perform maintenance on the suction impeller without first shutting down and positively locking out the power source and be sure the suction impeller has completely stopped rotating. **NOT FOLLOWING THESE PROCEDURES COULD RESULT IN SERIOUS PERSONAL INJURY OR DEATH.**

⚠️WARNING – Keep hands and feet away from the suction shroud opening and the leaf ingester mechanism at all times. Be sure the power source is shut down, positively locked out, and the impeller has completely stopped rotating before inspecting the suction shroud or leaf ingester mechanism. **NOT FOLLOWING THESE PROCEDURES COULD RESULT IN SERIOUS PERSONAL INJURY OR DEATH.**

⚠️WARNING – Personnel operating this equipment should wear ear and eye protection at all times. This equipment produces high decibel noise which could damage hearing over long term exposure. As with any piece of equipment of this nature, eye protection should always be worn to protect against flying debris. **NOT FOLLOWING THESE PROCEDURES COULD RESULT IN SERIOUS PERSONAL INJURY OR DEATH.**

⚠️WARNING – For all machines equipped with a hydraulically operated dumping leaf box the following procedures must be followed. No personnel is permitted on top of the machine. Machines equipped with top screening cannot support the weight of a person. Also, OSHA does not permit a person at an elevated height without the use of fall protection equipment. Prior to dumping the load it is imperative that the suction impeller has come to a complete stop. The operator(s) must be sure the machine will clear all overhead obstructions (power lines, tree limbs, etc.) prior to dumping. **NOT FOLLOWING THESE PROCEDURES COULD RESULT IN SERIOUS PERSONAL INJURY OR DEATH.**

FOR WARNING/NOTICE DECALS THAT ARE MISSING OR NOT LEGIBLE, OR FOR MANUAL REPLACEMENT COPIES, OR IF YOU HAVE QUESTIONS OR CONCERNS CONTACT FORT MILLER FAB3
(518)-584-4400 or www.fmfab3.com

HURRICANE

TABLE OF CONTENTS

Cover Page	1
Important Safety Information	2
Table of Contents	13
Safety Switches.....	14
Emergency Stop Location	15
Body Prop Location	17
Light Location	18
Decal Location	22
Decal Identification	26

⚠️ WARNING SAFETY SWITCHES NEED TO BE CHECKED FOR CORRECT OPERATION BEFORE EACH USE. DO NOT OPERATE MACHINERY WITH MALFUNCTIONING SAFETY SWITCHES. FAILURE TO COMPLY COULD RESULT IN SERIOUS PERSONAL INJURY OR DEATH.

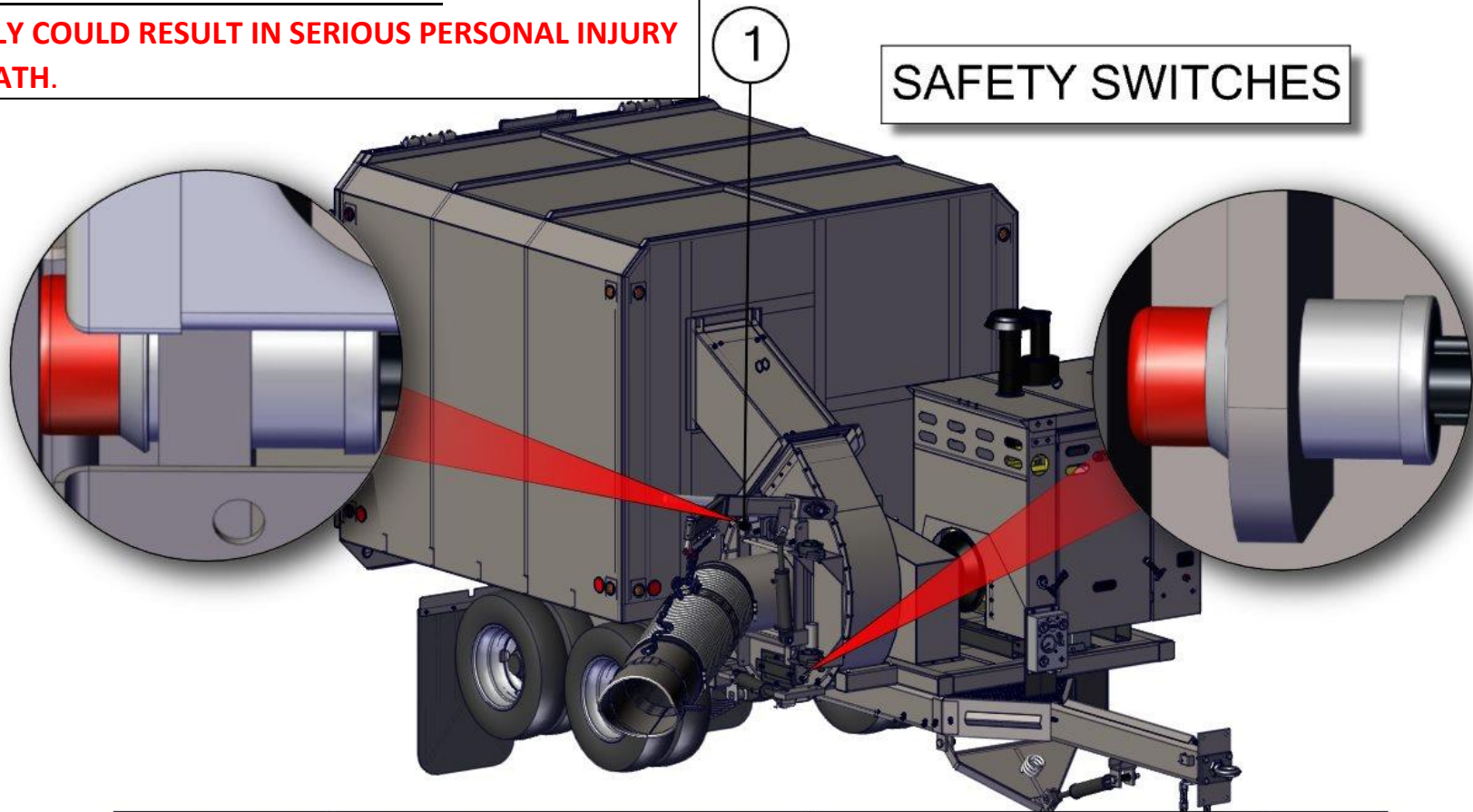

SAFETY SWITCHES

BOM ID	JDENumber (config)	Description (config)	Qty
1	31314	Switch, Safety	2

⚠ WARNING EMERGENCY STOPS NEED TO BE CHECKED FOR CORRECT OPERATION BEFORE EACH USE. DO NOT OPERATE MACHINERY WITH MALFUNCTIONING EMERGENCY STOPS. FAILURE TO COMPLY COULD RESULT IN SERIOUS PERSONAL INJURY OR DEATH.

1

EMERGENCY STOP LOCATION

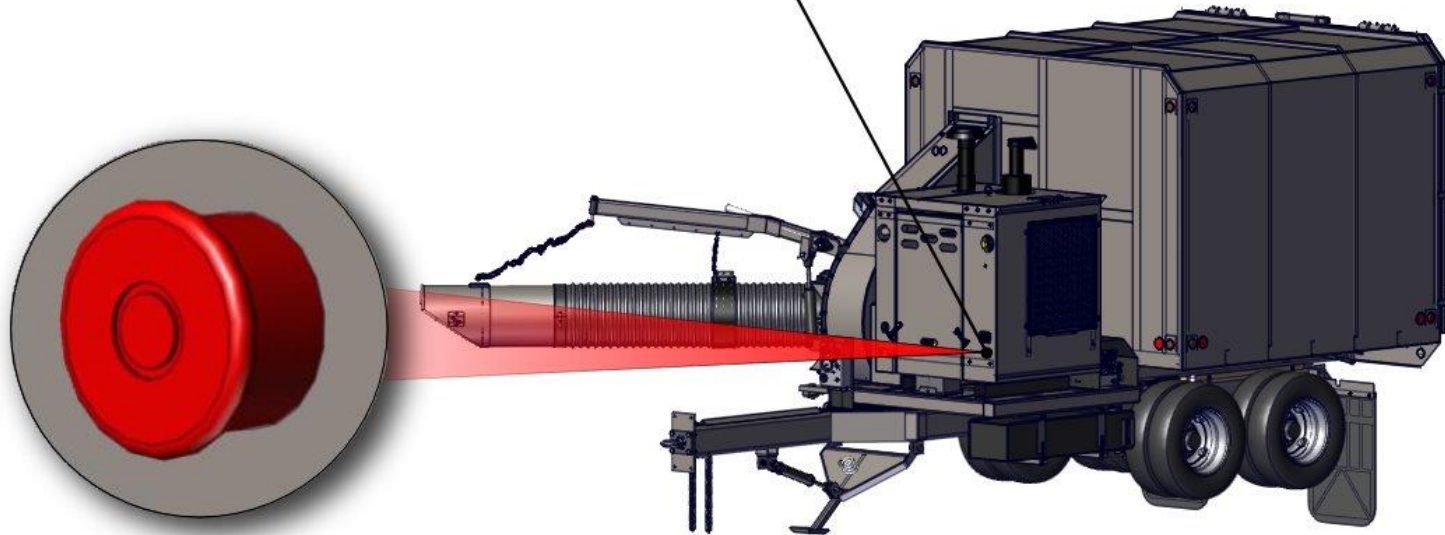

BOM ID	JDENumber (config)	Description (config)	Qty
1	33868	Mushroom Head Push Button	1

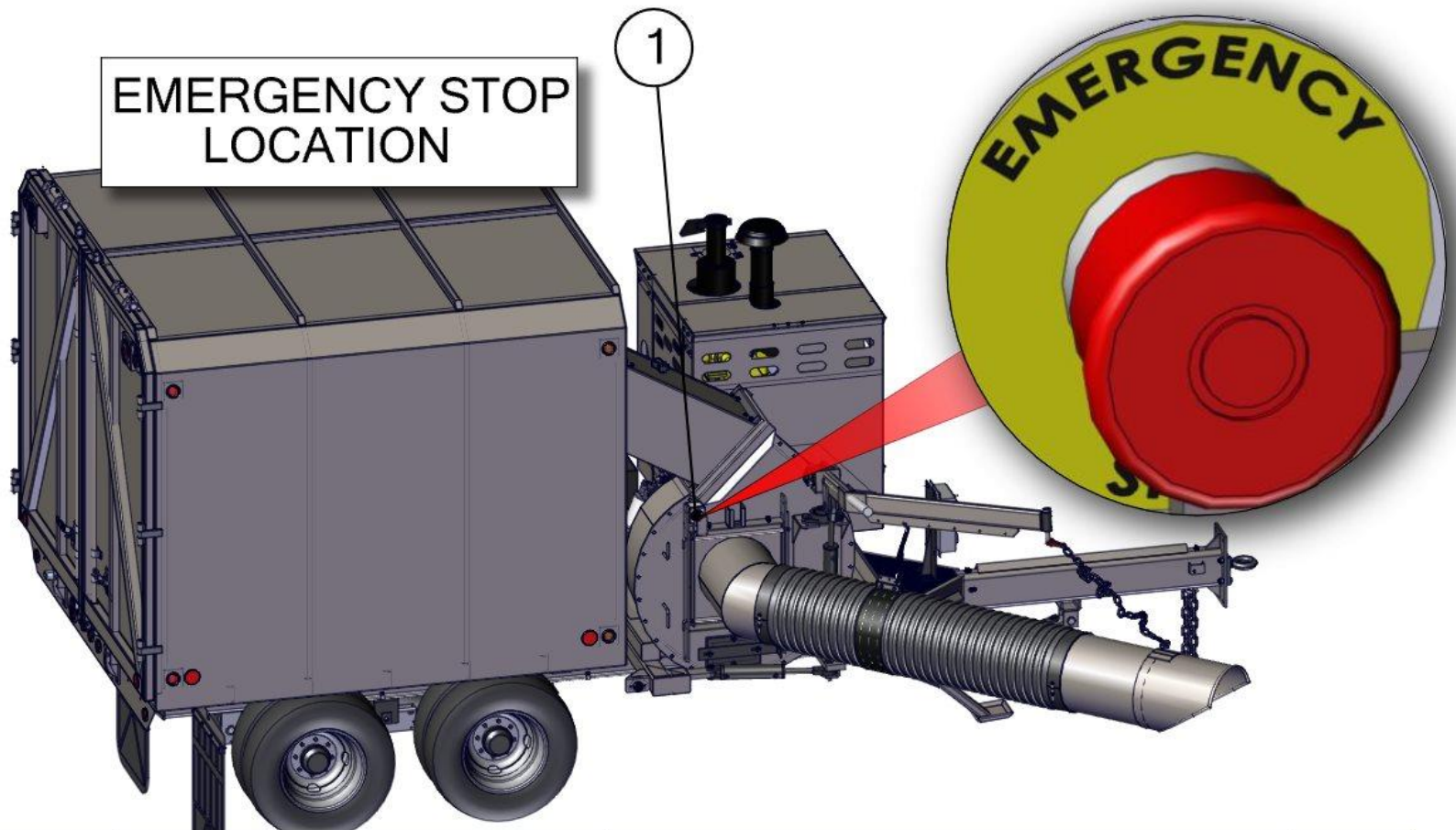

BOM ID	JDENumber (config)	Description (config)	Qty
1	33868	Mushroom Head Push Button	1



*****DO NOT GO UNDER DUMP BOX UNLESS BOX IS EMPTY AND PROPS ARE SECURED IN THE LOCKED OPEN POSITION*****



A WARNING SYMBOL INDICATES A HAZARDOUS SITUATION WHICH, IF NOT AVOIDED, COULD RESULT IN SERIOUS INJURY OR DEATH.

IF THE BODY LOWERS AND THE PROPS ARE NOT LOCKED IN PLACE ANY PERSON UNDER IT COULD BE CRUSHED TO DEATH OR HAVE SERIOUS INJURIES AS A RESULT.

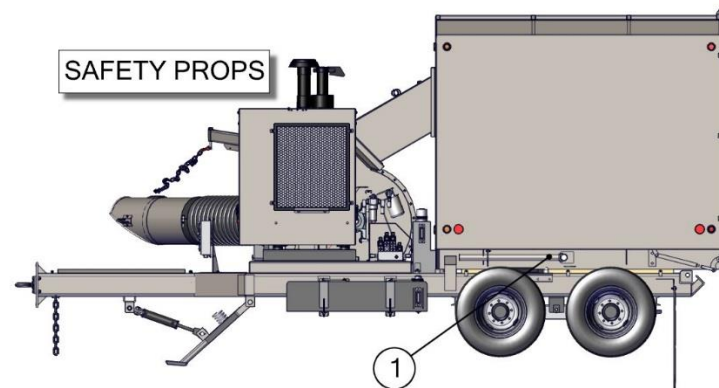

BOM ID	JDENumber (config)	Description (config)	Qty
1	28990	Safety Prop Assembly	2

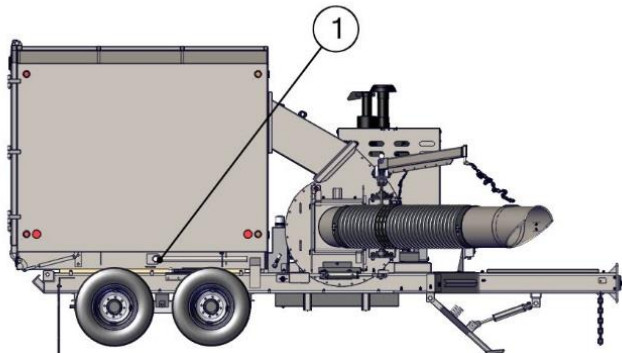

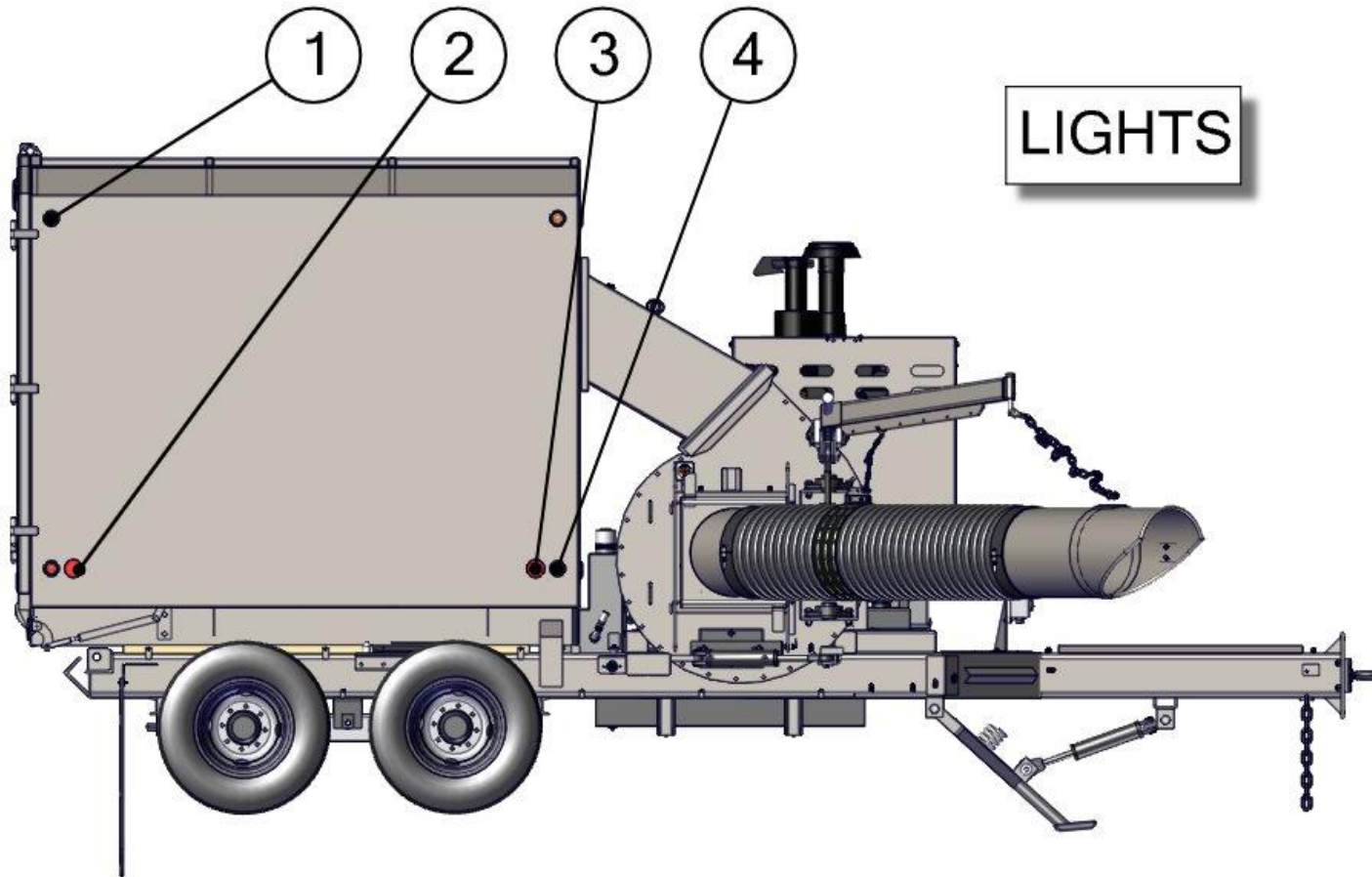

BOM ID	JDENumber (config)	Description (config)	Qty
1	27472	Red Light for T-2000 #146R	2
2	28043	Reflector-Red	1
3	28044	Reflector-Amber	1
4	331117	Light, 2" Round Amber	2

LIGHTS

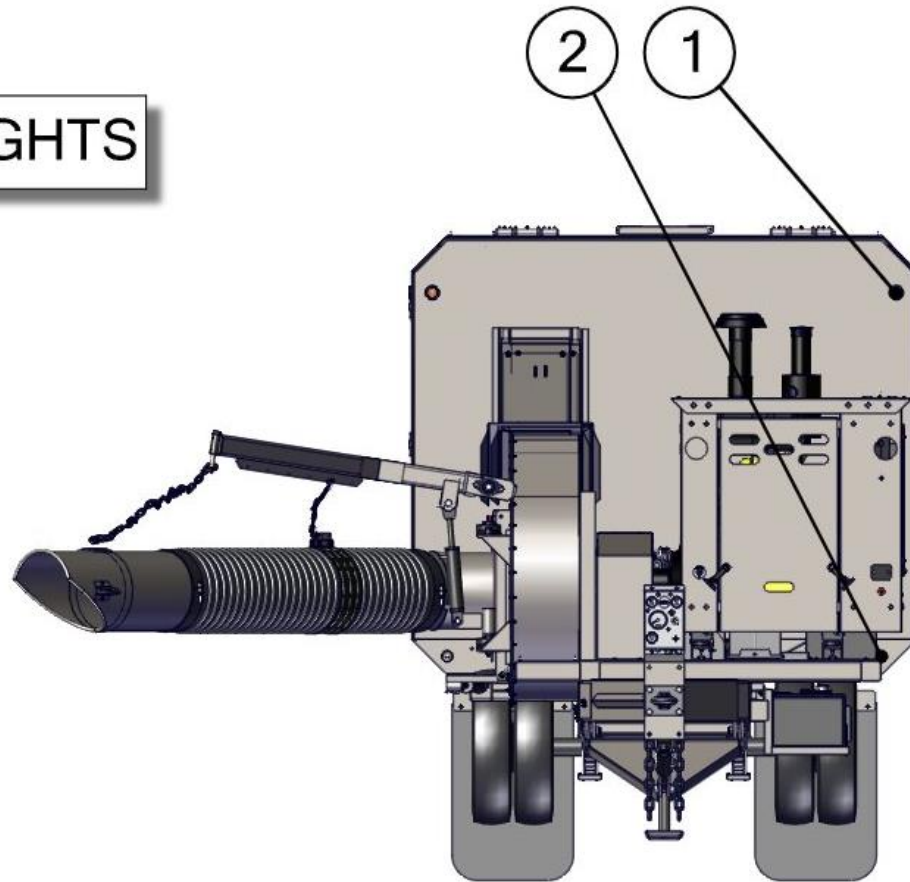

BOM ID	JDENumber (config)	Description (config)	Qty
1	33117	Light, 2" Round Amber	2
2	27472	Red Light for T-2000 #146R	2

LIGHTS

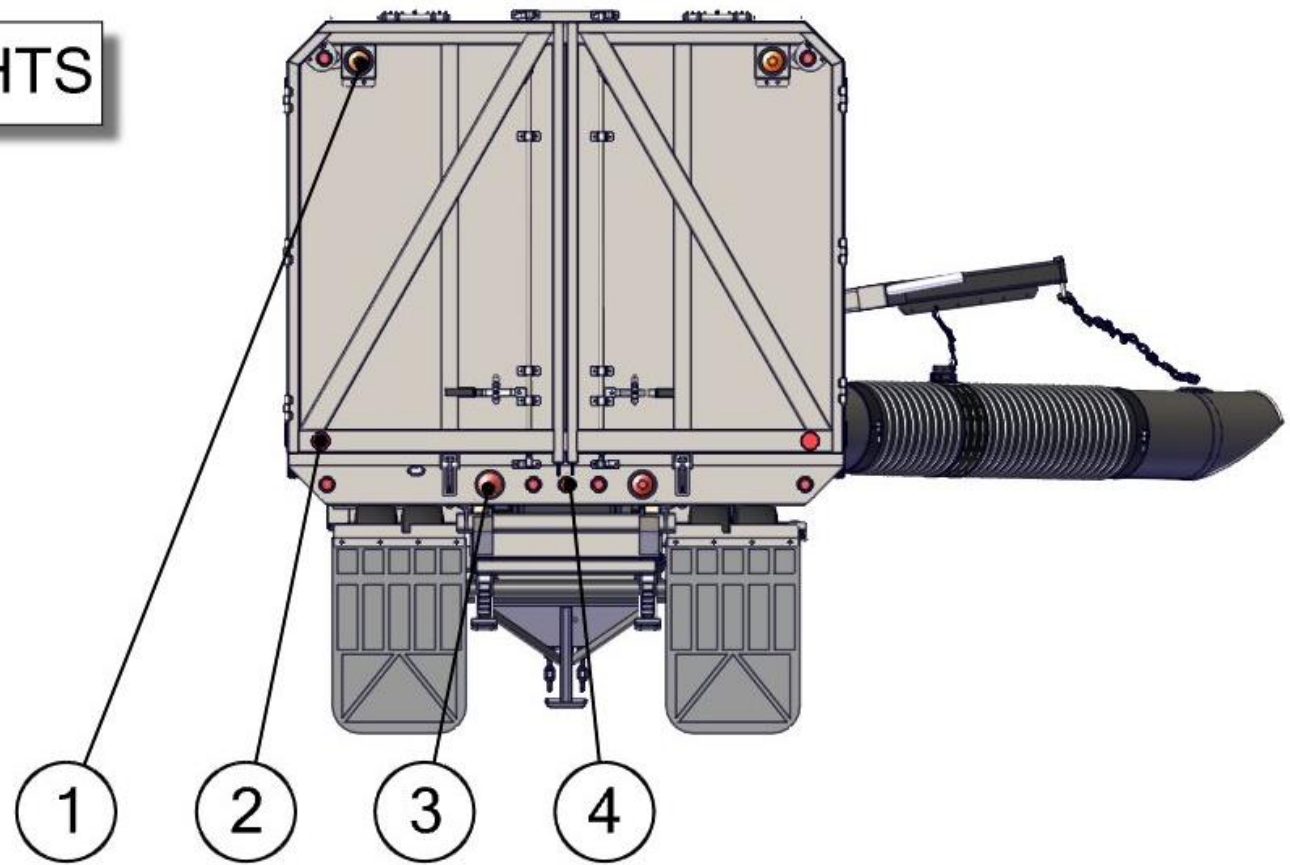

BOM ID	JDENumber (config)	Description (config)	Qty
1	33123	Light, Amber 4" Round	2
2	28043	Reflector-Red	2
3	28054	Light - Red	2
4	27472	Red Light for T-2000 #146R	7

LIGHTS

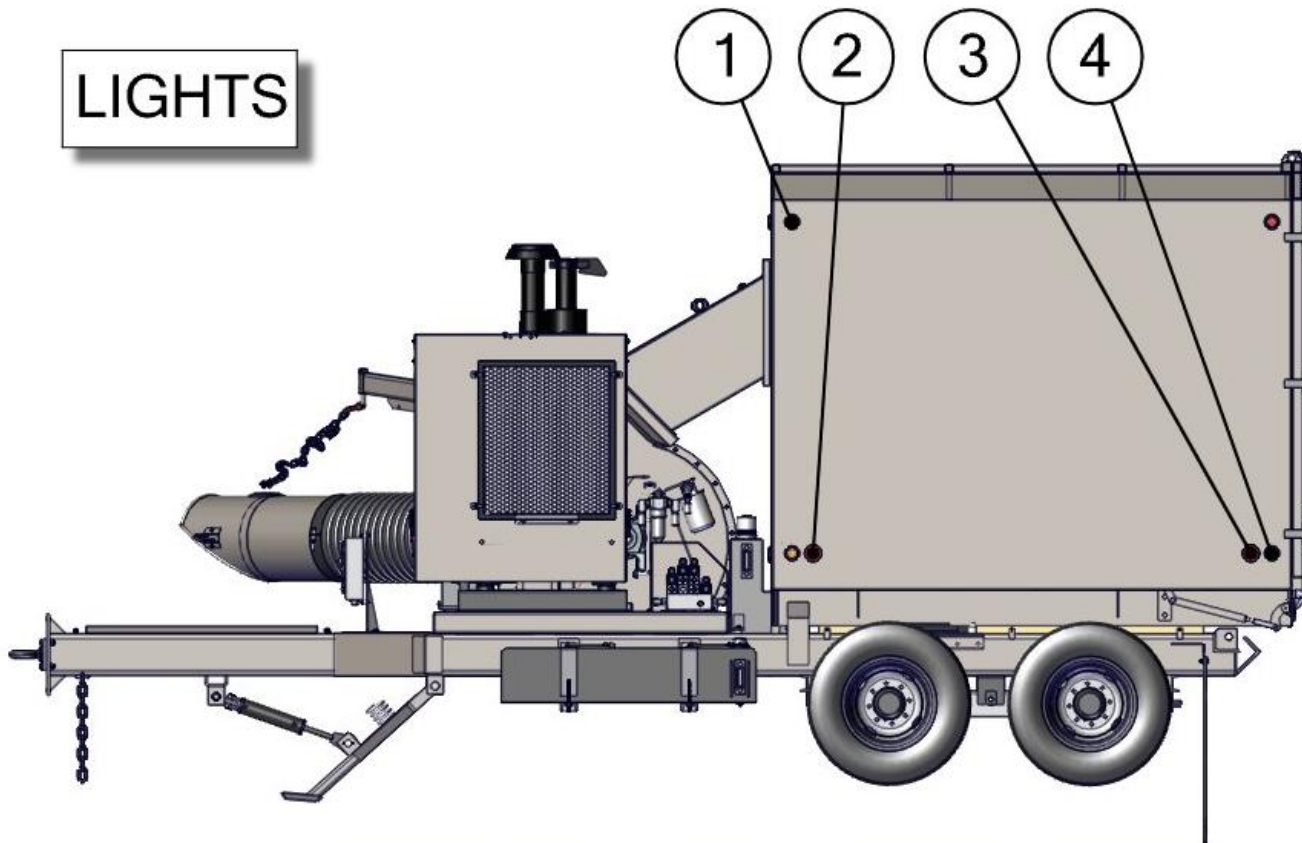

BOM ID	JDENumber (config)	Description (config)	Qty
1	33117	Light, 2" Round Amber	2
2	28044	Reflector-Amber	1
3	28043	Reflector-Red	1
4	27472	Red Light for T-2000 #146R	2

DECALS

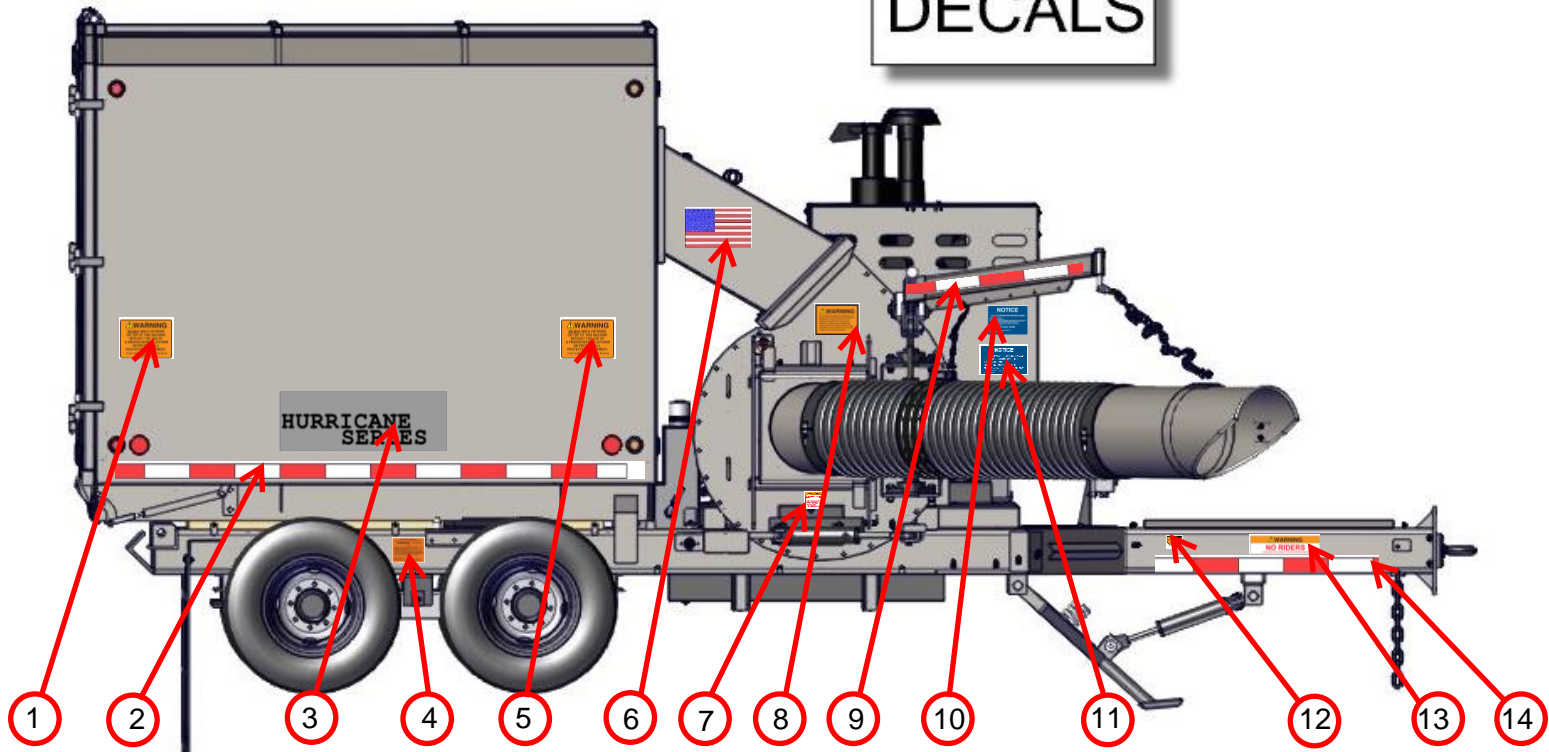

BOM ID	JDENumber	DESCRIPTION	QTY
1	27714	Decal - Do Not Walk or Work	1
2	28318	Tape-Conspicuity 2" Wide	1
3	33533	Decal "Hurricane Series"Black	1
4	27501	Decal - Caution Body Prop	1
5	27714	Decal - Do Not Walk or Work	1
6	27571	Decal - American Flag	1

7	27507	Decal - Safety First	1
8	27548	Decal - Warning Danger Stay	1
9	28318	Tape-Conspicuity 2" Wide	1
10	27503	Decal - Mylar-Do Not Engage or	1
11	27497	Decal - Clutch Operating	1
12	27561	Decal - Danger - Keep Hand and	1
13	27488	Decal - No Riders	1
14	28318	Tape-Conspicuity 2" Wide	1

DO NOT OPERATE EQUIPMENT IF ANY DECALS THAT CAME WITH THE PRODUCT OR WERE LATER SENT TO YOU BY FORT MILLER FAB3 ARE MISSING OR DAMAGED. THE ABOVE DIAGRAM ILLUSTRATES THE LOCATION AND NATURE OF THE WARNINGS THAT MUST BE ON THE PRODUCT: TO OBTAIN REPLACEMENT DECALS THAT ARE MISSING OR DAMAGED CONTACT FORT MILLER FAB3 AT (518)584-4400 OR WWW.FMFAB3.COM

DECALS

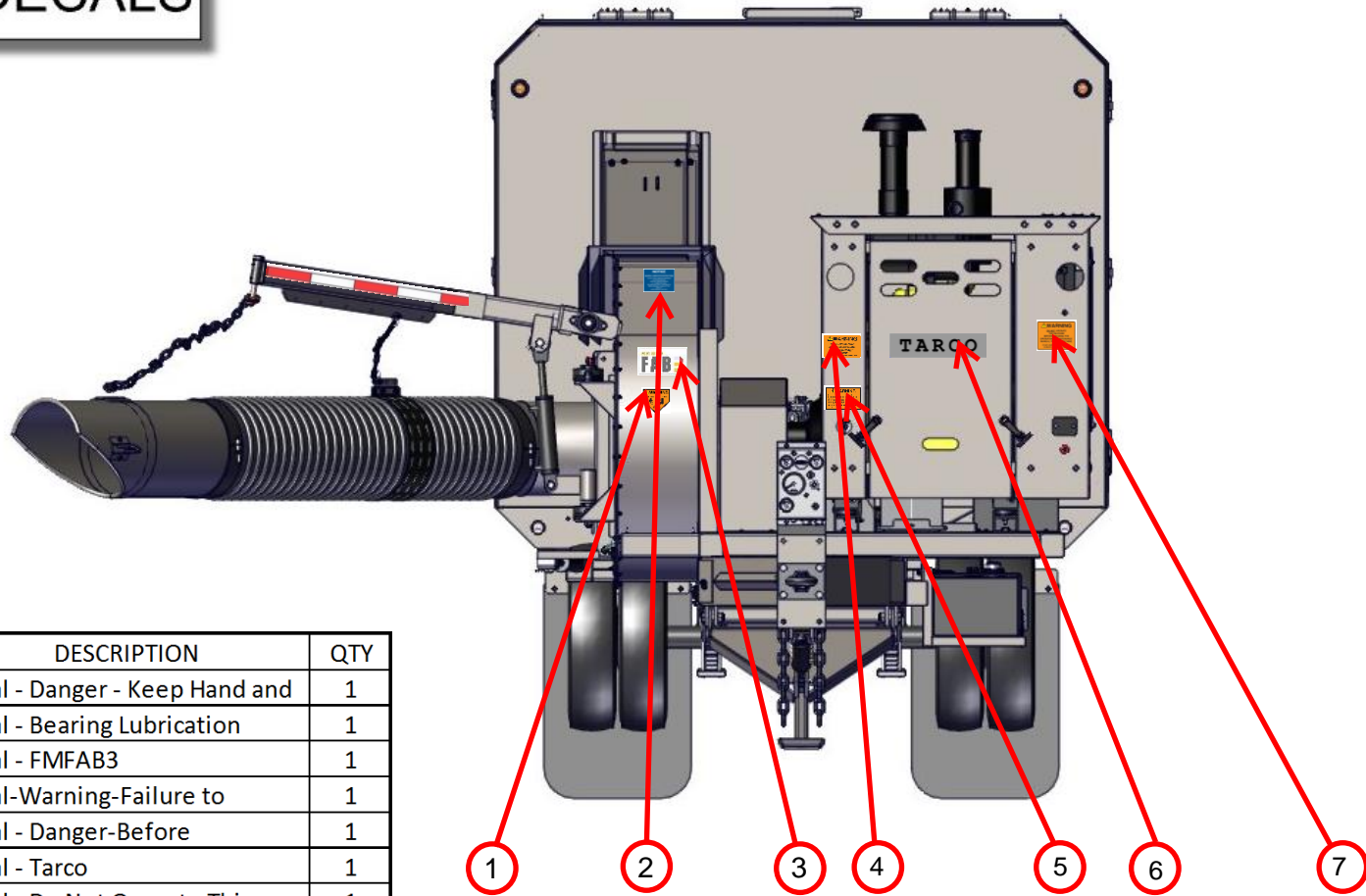

BOM ID	JDENumber	DESCRIPTION	QTY
1	27561	Decal - Danger - Keep Hand and	1
2	27490	Decal - Bearing Lubrication	1
3	29759	Decal - FMFAB3	1
4	27569	Decal-Warning-Failure to	1
5	27542	Decal - Danger-Before	1
6	27585	Decal - Tarco	1
7	27713	Decal - Do Not Operate This	1

DO NOT OPERATE EQUIPMENT IF ANY DECALS THAT CAME WITH THE PRODUCT OR WERE LATER SENT TO YOU BY FORT MILLER FAB3 ARE MISSING OR DAMAGED. THE ABOVE DIAGRAM ILLUSTRATES THE LOCATION AND NATURE OF THE WARNINGS THAT MUST BE ON THE PRODUCT: TO OBTAIN REPLACEMENT DECALS THAT ARE MISSING OR DAMAGED CONTACT FORT MILLER FAB3 AT (518)584-4400 OR WWW.FMFAB3.COM

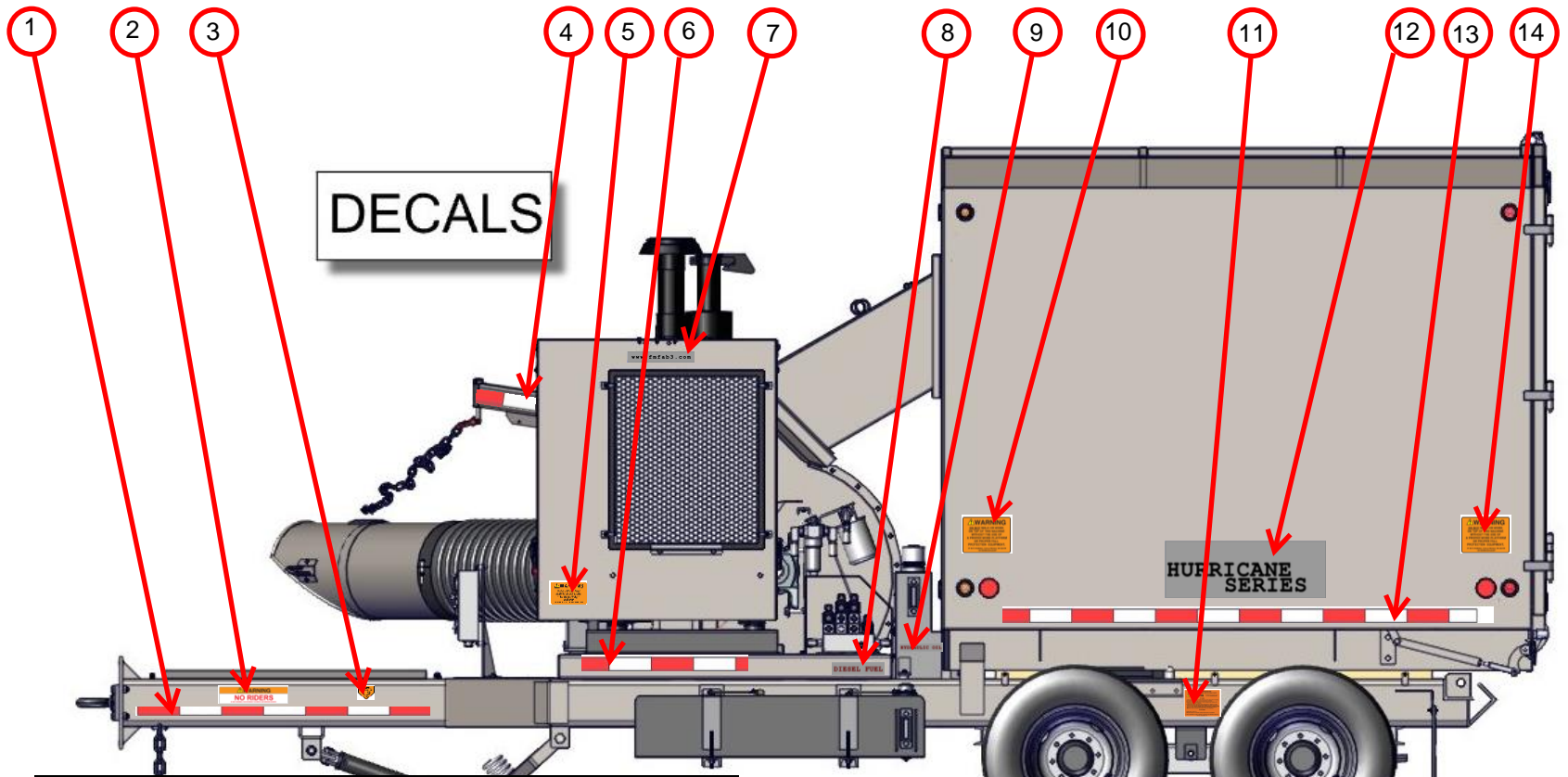

BOM ID	JDENumber	DESCRIPTION	QTY
1	28318	Tape-Conspicuity 2" Wide	1
2	27488	Decal - No Riders	1
3	27561	Decal - Danger - Keep Hand and	1
4	28318	Tape-Conspicuity 2" Wide	1
5	27569	Decal-Warning-Failure to	1
6	28318	Tape-Conspicuity 2" Wide	1
7	29761	Decal - www.FMFAB3.COM	1

8	27578	Decal - Diesel Fuel	1
9	27574	Decal - Hydraulic Oil	1
10	27714	Decal - Do Not Walk or Work	1
11	27501	Decal - Caution Body Prop	1
12	28318	Tape-Conspicuity 2" Wide	1
13	33533	Decal "Hurricane Series"Black	1
14	28318	Tape-Conspicuity 2" Wide	1
15	27714	Decal - Do Not Walk or Work	1

DO NOT OPERATE EQUIPMENT IF ANY DECALS THAT CAME WITH THE PRODUCT OR WERE LATER SENT TO YOU BY FORT MILLER FAB3 ARE MISSING OR DAMAGED. THE ABOVE DIAGRAM ILLUSTRATES THE LOCATION AND NATURE OF THE WARNINGS THAT MUST BE ON THE PRODUCT: TO OBTAIN REPLACEMENT DECALS THAT ARE MISSING OR DAMAGED CONTACT FORT MILLER FAB3 AT (518)584-4400 OR WWW.FMFAB3.COM

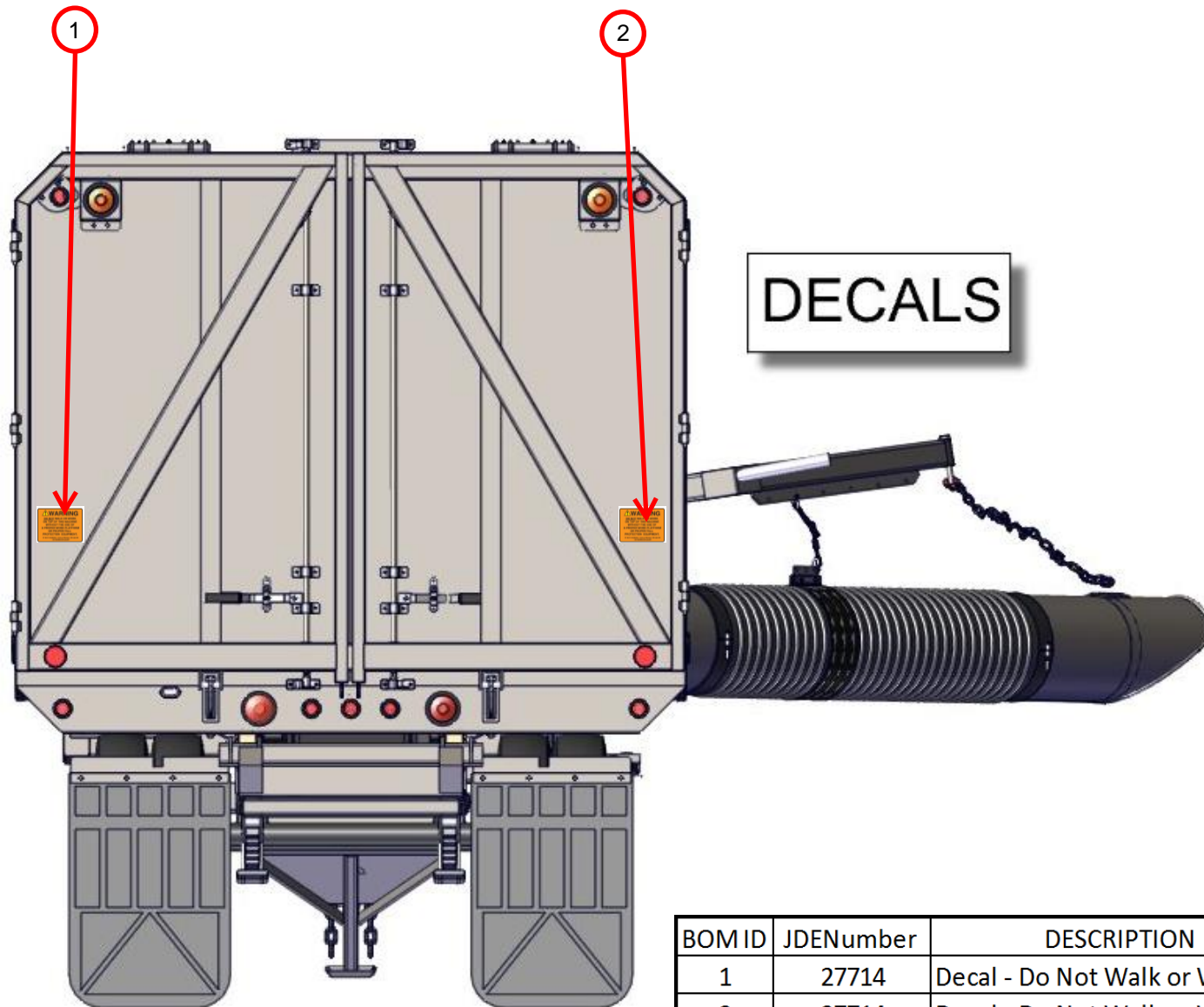

BOM ID	JDENumber	DESCRIPTION	QTY
1	27714	Decal - Do Not Walk or Work	1
2	27714	Decal - Do Not Walk or Work	1

DO NOT OPERATE EQUIPMENT IF ANY DECALS THAT CAME WITH THE PRODUCT OR WERE LATER SENT TO YOU BY FORT MILLER FAB3 ARE MISSING OR DAMAGED. THE ABOVE DIAGRAM ILLUSTRATES THE LOCATION AND NATURE OF THE WARNINGS THAT MUST BE ON THE PRODUCT: TO OBTAIN REPLACEMENT DECALS THAT ARE MISSING OR DAMAGED CONTACT FORT MILLER FAB3 AT (518)584-4400 OR WWW.FMFAB3.COM

DECAL IDENTIFICATION

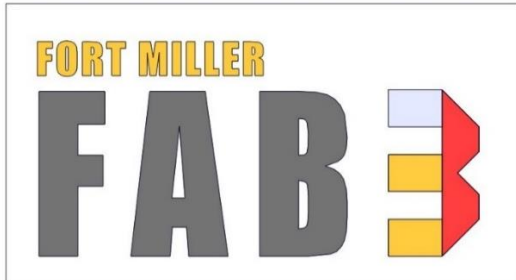

COMPANY LOGO

LOCATION DETAIL SEE PAGE 23 ITEM 4

JDE# 29759 (7500-1) QTY=1

HYDRAULIC OIL

JDE# 27574 (7500-91) QTY=1

NOTICE

**MACHINE DAMAGE WILL RESULT IF
NOT FOLLOWED**

LOCATION DETAIL SEE PAGE 24 ITEM 7



JDE# 27507 (7500-36) QTY=1



JDE# 27542 (7500-43) QTY=1

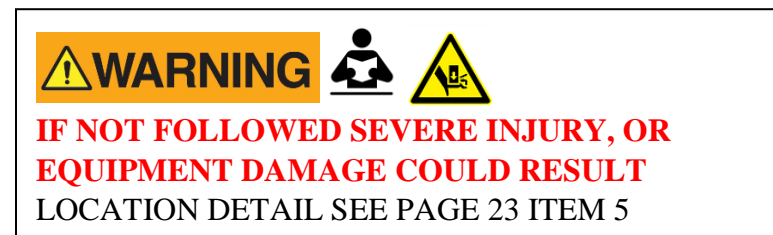

DIESEL FUEL

JDE# 27578 (7500-92) QTY=1



JDE# 27651 (7500-87) QTY=3

NOTICE

MACHINE DAMAGE WILL RESULT IF NOT FOLLOWED

LOCATION DETAIL SEE PAGE 24 ITEM 8



IF NOT FOLLOWED SEVERE INJURY, COULD RESULT

LOCATION DETAIL SEE PAGE 22 ITEM 12

LOCATION DETAIL SEE PAGE 23 ITEM 1

LOCATION DETAIL SEE PAGE 24 ITEM 3



JDE# 27569 (7500-89) QTY=2

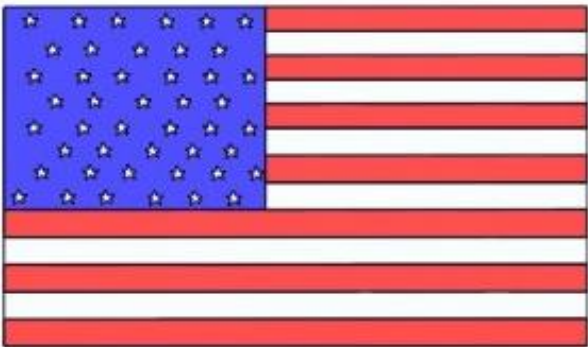

JDE# 27571 (7500-90) QTY=1



HURRICANE SERIES

JDE# 33533 (33533) QTY=2



JDE# 27713 (7500-98) QTY=1

MACHINE NAME

LOCATION DETAIL SEE PAGE 22 ITEM 3

LOCATION DETAIL SEE PAGE 24 ITEM 12



IF NOT FOLLOWED SEVERE INJURY,
DEATH OR EQUIPMENT DAMAGE COULD
RESULT

LOCATION DETAIL SEE PAGE 23 ITEM 7



JDE# 27714 (7500-99) QTY=6

TARCO

JDE# 27585 (7500-94) QTY=1



COMPANY BRAND
LOCATION DETAIL SEE PAGE 23 ITEM 6

www.fmfab3.com

JDE# 29761 (7500-101) QTY=1

CONTACT INFORMATION

LOCATION DETAIL SEE PAGE 24 ITEM 6

JDE# 28318 (60033-56) QTY=336"

 **CAUTION**

USE CAUTION POTENTIAL HAZARD

LOCATION DETAIL SEE PAGE 22 ITEM 2
LOCATION DETAIL SEE PAGE 22 ITEM 9
LOCATION DETAIL SEE PAGE 22 ITEM 14
LOCATION DETAIL SEE PAGE 24 ITEM 1
LOCATION DETAIL SEE PAGE 24 ITEM 5
LOCATION DETAIL SEE PAGE 24 ITEM 11
LOCATION DETAIL SEE PAGE 24 ITEM 13

 **WARNING**

NO RIDERS

IF NOT AVOIDED, COULD RESULT IN DEATH OR SERIOUS INJURY.

JDE# 27488 (7500-102) QTY=2

 **WARNING**



IF NOT FOLLOWED SEVERE INJURY, OR DEATH COULD RESULT

LOCATION DETAIL SEE PAGE 22 ITEM 13
LOCATION DETAIL SEE PAGE 24 ITEM 2

NOTICE

DO NOT ENGAGE OR DISENGAGE CLUTCH IF ENGINE EXCEEDS 800 - 1000 R.P.M
FREQUENT INITIAL CLUTCH ADJUSTMENTS ARE NECESSARY.
(SEE CLUTCH PTO INSTRUCTION BOOK FURNISHED WITH ENGINE.)

JDE# 27503 (7500-34) QTY=1

NOTICE

MACHINE DAMAGE WILL RESULT IF NOT FOLLOWED
LOCATION DETAIL SEE PAGE 22 ITEM 10



WARNING

Do not enter the blower housing inlet area without first shutting down and locking out the blower and power source. Do not attempt to inspect, clean, lubricate or perform any maintenance without first shutting down and locking out the blower and power source. Failure to do so could result in serious personal injury.

JDE# 27548 (7500-46) QTY=1



WARNING



IF NOT FOLLOWED SEVERE INJURY, OR EQUIPMENT DAMAGE COULD RESULT
LOCATION DETAIL SEE PAGE 22 ITEM 8

BODY PROP OPERATION
BE SURE BODY IS UNLOADED BEFORE USING PROPS

 **WARNING** WHEN TWO PROPS ARE INSTALLED ON THE VEHICLE BOTH MUST BE USED.

TO USE:

1. RAISE BODY TO A HEIGHT WHERE PROPS CAN BE SWUNG INTO POSITION.
2. BE SURE HOIST CONTROL VALVE IS IN NEUTRAL POSITION.
3. REMOVE TRANSIT POSITION BODY PROP RETAINERS AND SWING BODY PROPS INTO SUPPORT POSITION.
4. LOWER BODY ONTO THE BODY PROPS AND VISUALLY INSPECT TO SEE THAT BOTH ARE SECURE BEFORE PREFORMING ANY WORK. IF HOIST IS DOUBLE ACTING, **DO NOT POWER BODY DOWN ON PROPS (GRAVITY LOWER ONLY)**, BE SURE HOIST CONTROL VALVE IS IN THE NEUTRAL POSITION WITH THE LEVER LOCKOUT ENGAGED IN THE LOCK POSITION.

TO STORE:

5. RAISE BODY SLIGHTLY.
6. RETURN PROPS TO TRANSIT POSITION AND INSTALL RETAINERS.

IF NOT AVOIDED, COULD RESULT IN DEATH OR SERIOUS INJURY.
FM FAB3, GREENWICH, NY

 **WARNING** 

IF NOT FOLLOWED SEVERE INJURY, OR EQUIPMENT DAMAGE COULD RESULT
LOCATION DETAIL SEE PAGE 22 ITEM 4
LOCATION DETAIL SEE PAGE 24 ITEM 10

JDE# 27501 (7500-32) QTY=2

NOTICE

BEARING LUBRICATION INSTRUCTIONS

DO NOT OVER LUBRICATE BEARINGS
OUTDOOR SERVICE
(PER MFG. SPECIFICATIONS)
2 - 3 TIMES PER YEAR
RELUBRICATE UNTIL A THIN BEAD OF
FRESH GREASE IS VISIBLE AT THE
SEAL LIP
HAND GREASE GUN ONLY!

NOTICE

MACHINE DAMAGE WILL RESULT IF NOT FOLLOWED
LOCATION DETAIL SEE PAGE 23 ITEM 2

JDE# 27490 (7500-103) QTY=1

NOTICE

CLUTCH OPERATING INSTRUCTIONS

1. START AND WARM UP ENGINE
2. SET THROTTLE AT 1000 RPM & LOCK
3. ENGAGE THE CLUTCH WITH A FIRM GRADUALLY INCREASING PUSH ON THE CLUTCH LEVER UNTIL THE CLUTCH SNAPS INTO ENGAGEMENT. (HOLD "MURPHY" BUTTON IN TO AVOID AUTOMATIC SHUTDOWN) (CLUTCH HANDLE FORCE 60 TO 70 POUNDS.)
4. AFTER CLUTCH IS ENGAGED SET ENGINE TO DESIRED OPERATING SPEED
DO NOT EXCEED 2200 R.P.M.'S.

TO SHUT DOWN

1. SET THROTTLE TO IDLE
2. DISENGAGE CLUTCH (PULL HANDLE TOWARDS YOU)
3. IDLE ENGINE FOR FEW MINUTES
4. TURN ENGINE OFF.

NOTICE

**MACHINE DAMAGE WILL RESULT IF
NOT FOLLOWED**

LOCATION DETAIL SEE PAGE 22 ITEM 11

JDE# 27497 (7500-20) QTY=1